

Flexible Metallic Hose, Braid and Assemblies





Romeoville, Illinois



Houston, Texas



Springfield, Massachusetts

One source for all your flexible hose needs: Metal, Composite and Fluoropolymer hose and assemblies

For over 100 years, the US Hose® Corp has remained the preeminent manufacturer of metal, fluoropolymer and composite hose products. As part of US Hose/Titeflex, our factories in Romeoville, Illinois, Houston, Texas and Springfield, Massachusetts complement an impressive global network of specialty hose manufacturing facilities throughout North America and Europe..

Our diverse product line coupled with unparalleled engineering and customer service support enables us to provide our customers with a flexible hose solution for nearly any liquid and gaseous transfer application.

Quick Reference Hose Pressure Chart.....	Page 4
T321 Slip-On Stainless Steel Braid Specifications.....	Page 4
Series 460/860.....	Page 5
ISO 10380 Certified UFBX Hose on Reels.....	Page 6
UFBX (T316L).....	Page 7
AFBX Hose on Reels.....	Page 8
480 Large Diameter.....	Page 9
880 Large Diameter.....	Page 10
400M Large Diameter.....	Page 11
400H Large Diameter.....	Page 12
402X Ultra High Pressure.....	Page 13
403XM Ultra High Pressure.....	Page 13
403XMI Ultra High Pressure – Inconel®.....	Page 13
404XM Ultra High Pressure.....	Page 13
RF-67-XFC Ultra High Pressure.....	Page 14
AFCX and 280X/286X Super Flexible Hoses.....	Page 15
Monel® 400 Hose and Braid.....	Page 16
Inconel® Hose.....	Page 17
Hastelloy® Hose.....	Page 17
Corrugated Metal Hose Fittings.....	Pages 18 thru 20
Metal Hose Selection Factors.....	Pages 21 thru 23
Chart for Live Length of Hose in Offset.....	Page 24
Laboratory Corrosion Data Chart.....	Pages 25 thru 26
Metal Hose Installation Data.....	Pages 27 thru 28
Reference Charts.....	Pages 29 thru 30
RT-6 Interlocked Hose.....	Page 31
Notes.....	Pages 32 thru 34
STAMPED.....	Page 35

Maximum Working Pressure in PSI at 70° F

Product Type	Diameter																
	1/4"	3/8"	1/2"	3/4"	1"	1-1/4"	1-1/2"	2"	2-1/2"	3"	3-1/2"	4"	5"	6"	8"	10"	12"
T321 pg. 4	-	1100	796	597	455	441	370	370	-	-	-	-	-	-	-	-	-
Series 461/861 pg. 5	2240	1450	1040	600	580	450	410	-	-	-	-	-	-	-	-	-	-
Series 462/862 pg. 5	-	2430	1665	1080	1035	820	650	-	-	-	-	-	-	-	-	-	-
UFBX-1 T321 pg. 6	2420	1450	1075	950	725	563	500	478	377	320	-	-	-	-	-	-	-
UFBX-2 T321 pg. 6	3190	2580	1500	1250	1110	825	800	638	667	580	-	-	-	-	-	-	-
UFBX-1 T316 pg. 7	2420	1450	1375	1040	940	667	580	478	-	-	-	-	-	-	-	-	-
UFBX-2 T316 pg. 7	3190	2580	2230	1900	1480	1230	1045	870	-	-	-	-	-	-	-	-	-
AFBX-1 pg. 8	1825	1350	1200	875	900	515	435	425	-	-	-	-	-	-	-	-	-
AFBX-2 pg. 8	-	-	-	-	-	800	800	600	-	-	-	-	-	-	-	-	-
480 pg. 9	-	-	-	-	-	-	-	450	390	250	-	210	167	-	-	-	-
481 pg. 9	-	-	-	-	-	-	-	380	450	450	305	315	310	200	295	210	200
482 pg. 9	-	-	-	-	-	-	-	580	670	770	340	460	310	200	345	380	365
881 pg. 10	-	-	-	-	-	-	-	400	500	375	340	260	340	210	220	185	180
882 pg. 10	-	-	-	-	-	-	-	580	670	550	620	465	435	310	340	330	315
401M pg. 11	2660	1610	1310	915	645	545	560	450	570	450	265	285	265	240	217	210	200
402M pg. 11	4500	2435	2355	1650	1165	980	1000	810	750	560	265	375	265	285	270	375	360
401H pg. 12	2660	1610	1310	915	645	545	560	450	570	450	340	285	350	240	275	250	180
402H pg. 12	4500	2900	2355	1650	1165	980	1000	810	1030	820	600	515	385	430	350	375	320
402X pg. 13	5300	3900	3600	3550	2800	2480	2200	1675	-	-	-	-	-	-	-	-	-
403XM pg. 13	-	-	-	-	-	-	-	-	-	1200	-	-	-	-	-	-	-
403XM-I pg. 13	-	-	-	-	-	-	-	-	-	1800	-	-	-	-	-	-	-
404XM pg. 13	-	-	-	-	-	-	-	-	-	-	-	1200	-	-	-	-	-
RF67-XFC pg. 14	12000	9000	8500	6800	6250	5500	5200	4350	-	3000	-	-	-	-	-	-	-
Bronze CP pg. 15	1310	975	735	595	460	430	390	280	-	-	-	-	-	-	-	-	-
USCX pg. 16	1825	1350	1200	875	900	515	435	425	-	-	-	-	-	-	-	-	-
280X/286X pg. 16	2240	1374	1028	598	567	447	392	-	-	-	-	-	-	-	-	-	-
501 Monel 400 pg. 17	2250	1575	835	600	420	315	565	415	-	225	-	-	-	-	-	-	-
502 Monel 400 pg. 17	3025	2050	1500	1080	755	570	1015	745	-	425	-	-	-	-	-	-	-
INCO1 Inconel 625 pg. 18	2660	1610	1310	915	645	545	560	460	-	440	-	270	-	-	-	-	-
HAS01 Hastelloy pg. 18	-	-	1550	915	645	575	585	470	-	-	-	-	-	-	-	-	-

T-321 Stainless Steel Slip-On Braid Specification

TYPICAL HOSE O.D. (IN.)	NOMINAL HOSE O.D. (IN.)	BRAID I.D. (IN.)	BRAID CONSTRUCTION	BRAID ANGLE	COVERAGE (%)	WORKING PRESSURE (LB/FT)	WEIGHT (LB/FT)
0.49	1/4	0.48	24x5x.0126	52	84.0	2600	0.07
0.49	1/4	.055	24x6x.016	52	96.1	4250	0.13
0.66	3/8	0.66	24x6x.0126	52	78.7	1610	0.08
0.66	3/8	0.79	24x7x.016	52	88.7	2340	0.15
0.84	1/2	0.84	24x8x.0126	52	80.8	1310	0.11
0.84	1/2	0.84	24x6x.024	52	95.3	3350	0.29
1.21	3/4	1.20	48x6x.0126	52	83.7	915	0.16
1.21	3/4	1.24	48x4x.024	52	92.4	2000	0.38
1.53	1	1.50	48x5x.024	52	93.8	1600	0.48
1.53	1	1.53	48x7x.0126	52	79.7	645	0.19
1.86	1 1/4	1.86	48x9x.0126	52	82.6	545	0.24
1.86	1 1/4	1.86	48x6x.024	52	92.8	1200	0.58
2.19	1 1/2	2.19	48x8x.016	52	80.5	560	0.34
2.19	1 1/2	2.61	48x8x.024	52	91.0	950	0.77
2.83	2	2.83	48x12x.016	52	92.5	450	0.57
2.83	2	3.11	48x10x.024	52	93.1	760	0.96
3.00	2 1/2	3.00	64x9x.020	52	94.5	570	0.73
3.57	3	3.57	64x10x.020	52	91.3	450	0.89
4.72	4	4.72	64x13x.020	45	95.5	285	1.29
7.00	6	7.00	64x15x.024	46	92.0	240	2.08
9.00	8	9.00	(96x17x.025)	55	89.0	261	3.39
11.25	10	11.25	(96x29x.020)	57	84.0	186	3.64
13.25	12	13.25	(96x29x.025)	47	97.0	179	6.54
14.50	14	14.50	(96x29x.025)	50	95.0	149	6.16
16.50	16	16.50	(96x29x.025)	48	92.0	111	6.37

460 and 860 Series

Construction:

460/T321 stainless steel hose
860/T316L stainless steel hose
 Series 300 stainless steel braid
 Helical construction
 Also available 1/4"–1 1/2" direct braided

Maximum Working Pressure:

Full vacuum up to 2240 psig depending on size and braid construction

Temperature:

Cryogenic to 1250°F.

Sizes:

1/4" through 1 1/2"

461 One Braid

462 Two Braid

NOMINAL HOSE I.D.	HOSE TYPE	HOSE O.D.	WEIGHT PER FT.	MIN.LIVE LENGTH FOR VIBRATION	MINIMUM BEND RADIUS		MAXIMUM WORKING PRESSURE	MAXIMUM TEST PRESSURE	NORMAL BURST PRESSURE
					STATIC BEND	DYNAMIC FLEXING			
1/4"	460	0.42	0.06	3.50	0.625	3.500	75	110	—
	461	0.48	0.13	3.50	0.625	3.500	2240	3360	8960
3/8"	460	0.57	0.09	4.00	0.875	4.000	50	75	—
	461	0.63	0.17	4.00	0.875	4.000	1450	2175	5800
	462	0.69	0.25	4.00	0.875	4.000	2430	3645	9720
1/2"	460	0.75	0.12	4.50	1.125	5.500	50	75	—
	461	0.81	0.21	4.50	1.125	5.500	1040	1560	4160
	462	0.87	0.30	4.50	1.125	5.500	1665	2498	6660
3/4"	460	1.04	0.18	5.50	1.500	6.000	30	45	—
	461	1.10	0.30	5.50	1.500	6.000	600	900	2400
	462	1.16	0.33	5.50	1.500	6.000	1080	1620	4320
1	460	1.36	0.28	6.25	2.000	7.000	25	37	—
	461	1.42	0.45	6.25	2.000	7.000	580	870	2320
	462	1.48	0.62	6.25	2.000	7.000	1035	1550	4140
1 1/4"	460	1.68	0.46	7.00	2.500	11.500	20	30	—
	461	1.74	0.66	7.00	2.500	11.500	450	675	1800
	462	1.80	0.86	7.00	2.500	11.500	820	1230	3275
1 1/2"	460	2.02	0.59	7.75	3.000	14.000	15	23	—
	461	2.09	0.83	7.75	3.000	14.000	410	615	1640
	462	2.16	1.07	7.75	3.000	14.000	650	975	260

Annular Hose Construction

One Braid Shown



UFBX (T321 SS)

Construction:

T321 stainless steel hose
Series 300 stainless steel braid
 Direct braided 1/4" through 2" on reels
 Annular construction

Maximum Working Pressure:

Full vacuum up to 3190 psig depending on size and braid configuration

Temperature:

Cryogenic to 1250°F

Sizes:

1/4" through 3"

UFBX0 Unbraided

UFBX1 One Braid

UFBX2 Two Braid

The UFBX product is designed and certified to ISO 10380 specifications.

NOMINAL HOSE I.D.	HOSE TYPE	HOSE O.D.	WEIGHT PER FT.	MIN.LIVE LENGTH FOR VIBRATION	MINIMUM BEND RADIUS STATIC BEND	MINIMUM BEND RADIUS DYNAMIC FLEXING	MAXIMUM WORKING PRESSURE	MAXIMUM TEST PRESSURE	NORMAL BURST PRESSURE
1/4"	UFBX0	0.40	0.05	3.00	0.630	4.300	145	218	—
	UFBX1	0.45	0.11	3.00	1.000	4.300	2420	3630	9680
	UFBX2	0.50	0.16	3.00	1.000	4.300	3190	4785	12760
3/8"	UFBX0	0.59	0.11	3.50	0.870	6.000	80	120	—
	UFBX1	0.64	0.18	3.50	1.500	6.000	1450	2175	5800
	UFBX2	0.69	0.25	3.50	1.500	6.000	2580	3870	10320
1/2"	UFBX0	0.77	0.11	4.25	0.940	6.500	80	120	—
	UFBX1	0.83	0.22	4.25	1.750	6.500	1075	1615	4300
	UFBX2	0.88	0.33	4.25	1.750	6.500	1500	2250	6000
3/4"	UFBX0	1.02	0.18	4.50	1.200	8.000	60	90	—
	UFBX1	1.08	0.35	4.50	2.750	8.000	950	1425	3800
	UFBX2	1.14	0.52	4.50	2.750	8.000	1250	1875	5000
1"	UFBX0	1.33	0.21	5.50	1.700	8.000	60	90	—
	UFBX1	1.41	0.47	5.50	3.500	8.000	725	1087	2900
	UFBX2	1.49	0.73	5.50	3.500	8.000	1110	1650	4470
1 1/4"	UFBX0	1.62	0.27	6.00	2.200	10.000	50	75	—
	UFBX1	1.70	0.57	6.00	4.500	10.000	563	845	2252
	UFBX2	1.78	0.87	6.00	4.500	10.000	825	1237	3300
1 1/2"	UFBX0	1.88	0.45	6.25	2.700	10.000	35	53	—
	UFBX1	1.95	0.94	6.25	5.000	10.000	500	750	2000
	UFBX2	2.05	1.43	6.25	5.000	10.000	800	1200	3200
2"	UFBX0	2.45	0.55	7.50	3.500	14.000	15	23	—
	UFBX1	2.53	1.00	7.50	7.630	14.000	478	717	1912
	UFBX2	2.61	1.50	7.50	7.630	14.000	638	957	2552
2 1/2"	UFBX0	3.01	1.30	7.50	4.500	16.000	15	23	—
	UFBX1	3.09	1.90	7.50	7.900	16.000	377	566	1508
	UFBX2	3.18	2.50	7.50	7.900	16.000	667	1001	2668
3"	UFBX0	3.54	1.50	8.75	5.100	18.000	15	23	—
	UFBX1	3.62	2.20	8.75	9.000	18.000	320	480	1280
	UFBX2	3.70	3.00	8.75	9.000	18.000	580	870	2320

UFBX (T316L)

Construction:

T316L stainless steel hose
Series 300 stainless steel braid
 Direct braided 1/4" through 2" on **reels**
 Annular construction

Maximum Working Pressure:

Full vacuum up to 3190 psig
 depending on size and braid
 configuration

Temperature:

Cryogenic to 1250°F

Sizes:

1/4" through 2"

The UFBX product is designed and certified to ISO 10380 specifications.

NOMINAL HOSE I.D.	HOSE TYPE	HOSE O.D.	WEIGHT PER FT.	MIN.LIVE LENGTH FOR VIBRATION	MINIMUM BEND RADIUS		MAXIMUM WORKING PRESSURE	MAXIMUM TEST PRESSURE	NORMAL BURST PRESSURE
					STATIC BEND	DYNAMIC FLEXING			
1/4"	UFBX0	0.40	0.06	3.00	0.630	4.000	145	218	—
	UFBX1	0.45	0.11	3.00	1.000	4.000	2420	3630	9680
	UFBX2	0.50	0.16	3.00	1.000	4.000	3190	4785	12760
3/8"	UFBX0	0.59	0.11	4.25	0.870	6.000	80	120	—
	UFBX1	0.64	0.183	4.25	1.500	6.000	1450	2175	5800
	UFBX2	0.69	0.256	4.25	1.500	6.000	2580	3870	10320
1/2"	UFBX0	0.75	0.13	4.25	0.950	6.500	80	120	—
	UFBX1	0.81	0.24	4.25	1.750	6.500	1375	2063	5500
	UFBX2	0.87	0.35	4.25	1.750	6.500	2230	3345	8920
3/4"	UFBX0	1.00	0.24	4.50	1.200	7.900	60	90	—
	UFBX1	1.07	0.91	4.50	2.750	8.000	1040	1560	4160
	UFBX2	1.14	0.58	4.50	2.750	8.000	1900	2850	7600
1"	UFBX0	1.29	0.35	5.50	1.700	8.000	60	90	—
	UFBX1	1.39	0.61	5.50	3.500	8.000	940	1410	3760
	UFBX2	1.49	0.87	5.50	3.500	8.000	1480	2220	5920
1 1/4"	UFBX0	1.60	0.43	6.00	2.200	10.000	50	75	—
	UFBX1	1.69	0.73	6.00	4.250	10.000	667	1000	2668
	UFBX2	1.78	1.03	6.00	4.250	10.000	1230	1845	4920
1 1/2"	UFBX0	1.87	0.60	6.25	2.750	10.000	35	53	—
	UFBX1	1.96	1.09	6.25	5.000	10.000	580	870	2320
	UFBX2	2.05	1.58	6.25	5.000	10.000	1045	1568	4180
2"	UFBX0	2.43	0.77	7.50	3.500	14.000	15	23	—
	UFBX1	2.53	1.25	7.50	7.000	14.000	478	717	1912
	UFBX2	2.63	1.75	7.50	7.000	14.000	870	1305	3480
2-1/2"	UFBX0	3.01	1.30	7.50	4.500	16.000	15	23	—
	UFBX1	3.09	1.90	7.50	7.900	16.000	377	566	1508
	UFBX2	3.18	2.50	7.50	7.900	16.000	667	1001	2668
3"	UFBX0	3.54	1.50	8.75	5.100	18.000	15	23	—
	UFBX1	3.62	2.20	8.75	9.000	18.000	320	480	1280
	UFBX2	3.70	3.00	8.75	9.000	18.000	580	870	2320

AFBX

Construction:

T321 and **T316L** stainless steel hose

Series 300 stainless steel braid

Annular construction

Direct braided on reels - up to 500 feet

Maximum Working Pressure:

Full vacuum up to 1825 psig
depending on size

Sizes:

1/4" through 2"

Temperature:

Cryogenic to 1250°F

USBX Unbraided
USBX-2 Two Braid

USBX-1 One Braid

NOMINAL HOSE I.D.	HOSE TYPE	HOSE O.D.	WEIGHT PER FT.	MIN.LIVE LENGTH FOR VIBRATION	MINIMUM BEND RADIUS		MAXIMUM WORKING PRESSURE	MAXIMUM TEST PRESSURE	NORMAL BURST PRESSURE
					STATIC BEND	DYNAMIC FLEXING			
1/4"	USBX0	0.38	0.05	3.50	0.591	3.150	145	218	—
	USBX1	0.43	0.06	3.50	0.984	3.150	1825	2738	7300
3/8"	USBX0	0.56	0.07	4.50	0.709	5.039	80	120	—
	USBX1	0.61	0.16	4.50	1.496	5.039	1350	2025	5400
1/2"	USBX0	0.79	0.12	4.75	1.102	6.300	80	120	—
	USBX1	0.84	0.26	4.75	2.284	6.300	1200	1800	4800
3/4"	USBX0	1.06	0.17	5.25	1.260	6.614	60	90	—
	USBX1	1.11	0.33	5.25	2.756	6.614	875	1313	3500
1"	USBX0	1.27	0.23	5.50	1.575	7.480	60	90	—
	USBX1	1.34	0.52	5.50	3.346	7.480	900	1350	3600
1 1/4"	USBX0	1.62	0.29	7.50	1.969	10.039	50	75	—
	USBX1	1.67	0.53	7.50	4.134	10.039	515	773	2060
	USBX2	1.72	0.77	7.50	4.134	10.039	800	1200	3200
1 1/2"	USBX0	1.96	0.47	8.00	2.362	11.614	36	54	—
	USBX1	2.03	0.85	8.00	5.118	11.614	435	653	1740
	USBX2	2.10	1.23	8.00	5.118	11.614	800	1200	3200
2"	USBX0	2.38	0.60	9.50	2.756	12.598	15	23	—
	USBX1	2.44	1.06	9.50	6.299	12.598	425	638	1700
	USBX2	2.50	1.52	9.50	6.299	12.598	600	900	2400

480 Large Diameter Hose

Construction:

T321 stainless steel hose
Series 300 stainless steel braid
 Annular construction

Sizes:

2" through 12"

Maximum Working Pressure:

Full vacuum up to 670 psig
 depending on size and braid
 configuration

Temperature:

Cryogenic to 1500°F

480 Unbraided
481 One Braid
482 Two Braid

NOMINAL HOSE I.D.	HOSE TYPE	HOSE O.D.	WEIGHT PER FT.	MIN.LIVE LENGTH FOR VIBRATION	MINIMUM BEND RADIUS		MAXIMUM WORKING PRESSURE	MAXIMUM TEST PRESSURE	NORMAL BURST PRESSURE
					STATIC BEND	DYNAMIC FLEXING			
2 1/2"	480	3.11	1.00	11.00	7.000	16.000	6	9	—
	481	3.21	1.77	11.00	7.000	16.000	450	675	1800
	482	3.30	2.54	11.00	7.000	16.000	670	1005	2680
3"	480	3.57	1.35	11.00	8.250	19.000	4	6	—
	481	3.69	1.83	11.00	8.250	19.000	445	670	1780
	482	3.76	2.57	11.00	8.250	19.000	560	850	2240
3 1/2"	480	4.14	1.69	11.50	9.750	20.500	3	4	—
	481	4.26	1.91	11.50	9.750	20.500	265	400	1060
4"	480	4.72	1.66	12.00	11.000	22.000	2	3	—
	481	4.82	2.59	12.00	11.000	22.000	285	425	1140
	482	4.91	3.52	12.00	11.000	22.000	375	565	1500
5"	480	5.86	2.27	13.00	13.500	28.000	2.8	4	—
	481	5.96	3.57	13.00	13.500	28.000	265	500	1060
6"	480	7.00	3.53	14.00	16.000	34.000	3	4.5	—
	481	7.10	5.22	14.00	16.000	34.000	195	290	780
	482	7.19	6.91	14.00	16.000	34.000	195	290	780
8"	480	9.06	4.59	16.00	20.000	42.000	2	3	—
	481	9.16	7.91	16.00	20.000	42.000	220	325	870
	482	9.26	11.23	16.00	20.000	42.000	270	405	1080
10"	480	11.19	5.93	24.00	34.000	69.000	2	3	—
	481	11.29	10.30	24.00	34.000	69.000	210	315	840
	482	11.39	14.67	24.00	34.000	69.000	375	565	1500
12"	480	13.25	7.08	27.00	37.000	74.000	1.8	2.8	—
	481	13.35	13.62	27.00	37.000	74.000	200	300	800
	482	13.45	20.16	27.00	37.000	74.000	360	540	1440

880 Large Diameter Hose

Construction:

T316L stainless steel hose
Series 300 stainless steel braid
 Annular construction

Maximum Working Pressure:

Full vacuum up to 670 psig
 depending on size and braid
 configuration

Sizes:

2" through 12"

Temperature:

Cryogenic to 1500°F

880 Unbraided

881 One Braid

882 Two Braid

NOMINAL HOSE I.D.	HOSE TYPE	HOSE O.D.	WEIGHT PER FT.	MIN.LIVE LENGTH FOR VIBRATION	MINIMUM BEND RADIUS		MAXIMUM WORKING PRESSURE	MAXIMUM TEST PRESSURE	NORMAL BURST PRESSURE
					STATIC BEND	DYNAMIC FLEXING			
2 1/2"	880	3.11	1.24	11.00	7.000	16.000	6	9	—
	881	3.21	3.01	11.00	7.000	16.000	500	750	2000
	882	3.30	2.78	11.00	7.000	16.000	670	1005	2680
3"	880	3.57	1.35	11.00	8.250	19.000	4	6	—
	881	3.69	2.78	11.00	8.250	19.000	375	560	1500
	882	3.76	4.21	11.00	8.250	19.000	550	825	2200
3 1/2"	880	4.14	1.69	11.50	9.750	20.500	3	4	—
	881	4.26	2.54	11.50	9.750	20.500	340	510	1360
	882	4.48	3.40	11.50	9.750	20.500	620	930	2480
4"	880	4.72	2.06	12.00	11.000	22.000	2	3	—
	881	4.82	3.00	12.00	11.000	22.000	260	390	1050
	882	4.91	3.94	12.00	11.000	22.000	465	695	1860
5"	880	5.86	2.68	13.00	13.500	28.000	3	4	—
	881	5.96	3.98	13.00	13.500	28.000	340	510	1360
	882	6.06	5.28	13.00	13.500	28.000	435	650	1740
6"	880	7.00	4.44	14.00	16.000	34.000	3	4.5	—
	881	7.10	6.14	14.00	16.000	34.000	210	315	850
	882	7.19	7.87	14.00	16.000	34.000	310	465	1240
8"	880	9.06	5.70	16.00	20.000	42.000	2	3	—
	881	9.16	9.02	16.00	20.000	42.000	220	330	875
	882	9.26	12.34	16.00	20.000	42.000	340	510	1360
10"	880	11.19	5.93	24.00	34.000	69.000	2	3	—
	881	11.29	10.30	24.00	34.000	69.000	185	275	740
	882	11.39	14.67	24.00	34.000	69.000	330	495	1320
12"	880	13.25	7.08	27.00	37.000	74.000	2	3	—
	881	13.35	13.62	27.00	37.000	74.000	175	260	700
	882	13.45	20.16	27.00	37.000	74.000	315	470	1260

400M Hose

Construction:

T321 stainless steel hose

Series T321 stainless steel braid

Annular construction

Sizes:

1/4" through 12"

Maximum Working Pressure:

Full vacuum up to 4500 psig depending on size and braid configuration

Temperature:

Cryogenic to 1500°F

400M Unbraided

401M One Braid

402M Two Braid

NOMINAL HOSE I.D.	HOSE TYPE	HOSE O.D.	WEIGHT PER FT.	MIN.LIVE LENGTH FOR VIBRATION	MINIMUM BEND RADIUS		MAXIMUM WORKING PRESSURE	MAXIMUM TEST PRESSURE	NORMAL BURST PRESSURE
					STATIC BEND	DYNAMIC FLEXING			
1/4"	400M	0.49	0.14	3.75	0.875	5.500	200	300	—
	401M	0.55	0.21	3.75	0.875	5.500	2660	4000	10650
	402M	0.61	0.28	3.75	0.875	5.500	4500	6750	18000
3/8"	400M	0.66	0.18	4.25	1.125	5.500	100	150	—
	401M	0.73	0.25	4.25	1.125	5.500	1610	2415	6440
	402M	0.79	0.35	4.25	1.125	5.500	2435	3650	9750
1/2"	400M	0.84	0.27	4.50	1.500	6.000	80	120	—
	401M	0.90	0.38	4.50	1.500	6.000	1310	1965	5240
	402M	0.96	0.49	4.50	1.500	6.000	2355	3530	9420
3/4"	400M	1.21	0.51	5.50	2.125	8.000	70	105	—
	401M	1.27	0.67	5.50	2.125	8.000	915	1370	3660
	402M	1.33	0.84	5.50	2.125	8.000	1650	2475	6600
1"	400M	1.53	0.75	6.50	2.750	9.000	43	65	—
	401M	1.59	0.93	6.50	2.750	9.000	645	965	2580
	402M	1.65	1.13	6.50	2.750	9.000	1165	1745	4660
1 1/4"	400M	1.86	0.96	7.00	3.250	10.500	29	43	—
	401M	1.92	1.20	7.00	3.250	10.500	545	820	2180
	402M	1.98	1.45	7.00	3.250	10.500	980	1470	3920
1 1/2"	400M	2.19	1.47	7.50	3.750	12.000	31	47	—
	401M	2.27	1.85	7.50	3.750	12.000	560	840	2240
	402M	2.35	2.20	7.50	3.750	12.000	1000	1500	4000
2"	400M	2.83	1.97	9.00	5.000	15.000	17	26	—
	401M	2.91	2.44	9.00	5.000	15.000	450	675	1800
	402M	2.99	2.90	9.00	5.000	15.000	810	1215	3240
2 1/2"	400M	3.00	1.42	7.00	7.000	14.000	6.5	10	—
	401M	3.12	2.19	7.00	7.000	14.000	570	855	2280
	402M	3.24	2.96	7.00	7.000	14.000	750	1125	3000
3"	400M	3.57	1.82	8.00	8.250	17.000	4.5	6.8	—
	401M	3.69	2.70	8.00	8.250	17.000	450	675	1800
	402M	3.81	3.58	8.00	8.250	17.000	560	840	2240
3 1/2"	400M	4.14	1.57	9.00	9.500	19.000	3	5	—
	401M	4.26	2.43	9.00	9.500	19.000	265	398	1060
	402M	4.38	3.29	9.00	9.500	19.000	265	398	1060
4"	400M	4.72	2.38	10.00	11.000	22.000	2	3	—
	401M	4.84	3.34	10.00	11.000	22.000	285	425	1140
	402M	4.96	4.30	10.00	11.000	22.000	375	563	1500
5"	400M	5.93	3.20	17.50	11.000	28.000	2.8	4.3	—
	401M	6.03	4.50	17.50	11.000	28.000	265	400	1060
	402M	6.13	5.80	17.50	11.000	28.000	265	400	1060
6"	400M	7.00	4.46	17.00	16.500	33.000	3.5	5.3	—
	401M	7.19	6.20	17.00	16.500	33.000	240	360	960
	402M	7.38	7.94	17.00	16.500	33.000	285	428	1140
8"	400M	9.06	5.85	19.00	21.500	43.000	2.7	4.1	—
	401M	9.31	9.39	19.00	21.500	43.000	217	326	868
	402M	9.56	12.93	19.00	21.500	43.000	270	405	1080
10"	400M	11.19	9.17	21.00	27.000	54.000	2.2	3.3	—
	401M	11.44	13.54	21.00	27.000	54.000	210	315	840
	402M	11.69	17.91	21.00	27.000	54.000	375	563	1500
12"	400M	13.25	10.93	23.00	32.000	64.000	1.8	2.8	—
	401M	13.50	16.94	23.00	32.000	64.000	200	300	800
	402M	13.75	22.95	23.00	32.000	64.000	360	540	1440

400H Hose

Construction:

T316L stainless steel hose
Series T321 stainless steel braid
 Annular construction

Sizes:

1/4" through 12"

Maximum Working Pressure:

Full vacuum up to 4500 psig
 depending on size and braid
 configuration

Temperature:

Cryogenic to 1500°F

400H Unbraided
401H One Braid
402H Two Braid

NOMINAL HOSE I.D.	HOSE TYPE	HOSE O.D.	WEIGHT PER FT.	MIN.LIVE LENGTH FOR VIBRATION	MINIMUM BEND RADIUS		MAXIMUM WORKING PRESSURE	MAXIMUM TEST PRESSURE	NORMAL BURST PRESSURE
					STATIC BEND	DYNAMIC FLEXING			
1/4"	400H	0.49	0.14	3.75	0.875	5.500	265	400	—
	401H	0.55	0.21	3.75	0.875	5.500	2660	4000	10650
	402H	0.61	0.28	3.75	0.875	5.500	4500	6750	18000
3/8"	400H	0.66	0.21	4.50	1.125	6.000	133	200	—
	401H	0.73	0.29	4.50	1.125	6.000	1610	2415	6440
	402H	0.79	0.38	4.50	1.125	6.000	2900	4325	11600
1/2"	400H	0.84	0.36	5.00	1.500	7.000	133	200	—
	401H	0.90	0.47	5.00	1.500	7.000	1310	1965	5240
	402H	0.96	0.58	5.00	1.500	7.000	2355	3530	9420
3/4"	400H	1.21	0.71	5.75	2.125	8.500	100	150	—
	401H	1.27	0.87	5.75	2.125	8.500	915	1370	3660
	402H	1.33	1.04	5.75	2.125	8.500	1650	2475	6600
1"	400H	1.53	0.92	7.00	2.750	10.000	63	95	—
	401H	1.59	1.11	7.00	2.750	10.000	645	965	2580
	402H	1.65	1.30	7.00	2.750	10.000	1165	1745	4660
1 1/4"	400H	1.86	1.45	7.50	3.250	11.500	60	90	—
	401H	1.92	1.69	7.50	3.250	11.500	545	820	2180
	402H	1.98	1.94	7.50	3.250	11.500	980	1470	3920
1 1/2"	400H	2.19	1.78	8.00	3.750	13.000	43	65	—
	401H	2.27	2.10	8.00	3.750	13.000	560	840	2240
	402H	2.35	2.50	8.00	3.750	13.000	1000	1500	4000
2"	400H	2.83	2.38	9.50	5.000	16.000	23	34	—
	401H	2.91	2.84	9.50	5.000	16.000	450	675	1800
	402H	2.99	3.38	9.50	5.000	16.000	810	1215	3240
2 1/2"	400H	3.00	2.06	7.75	7.000	17.000	14	20	—
	401H	3.12	2.83	7.75	7.000	17.000	570	855	2280
	402H	3.24	3.74	7.75	7.000	17.000	1030	1545	4120
3"	400H	3.57	2.44	9.00	8.250	21.000	9	14	—
	401H	3.69	3.32	9.00	8.250	21.000	450	675	1800
	402H	3.81	4.30	9.00	8.250	21.000	820	1230	3280
3 1/2"	400H	4.14	2.95	10.00	9.500	25.000	7	10	—
	401H	4.26	3.81	10.00	9.500	25.000	340	510	1360
	402H	4.38	4.67	10.00	9.500	25.000	600	900	2400
4"	400H	4.72	3.20	10.75	11.000	27.000	4	6	—
	401H	4.84	4.16	10.75	11.000	27.000	285	425	1140
	402H	4.96	5.24	10.75	11.000	27.000	515	770	2060
5"	400H	5.93	3.20	17.50	11.000	28.000	4	6	—
	401H	6.03	4.50	17.50	11.000	28.000	350	525	1400
	402H	6.13	5.80	17.50	11.000	28.000	385	578	1540
6"	400H	7.00	5.58	19.00	16.500	41.000	6.5	9	—
	401H	7.19	7.32	19.00	16.500	41.000	240	360	960
	402H	7.38	9.06	19.00	16.500	41.000	430	645	1720
8"	400H	9.06	7.37	21.00	21.500	54.000	5	7.5	—
	401H	9.31	10.91	21.00	21.500	54.000	275	410	1100
	402H	9.56	14.45	21.00	21.500	54.000	350	525	1400
10"	400H	11.19	8.29	27.00	34.000	68.000	2.2	3.3	—
	401H	11.44	12.66	27.00	34.000	68.000	250	375	1000
	402H	11.69	17.03	27.00	34.000	68.000	375	563	1500
12"	400H	13.25	9.94	31.00	42.000	83.000	1.8	2.8	—
	401H	13.45	16.48	31.00	42.000	83.000	180	270	720
	402H	13.65	23.02	31.00	42.000	83.000	320	480	1280

Annular Hose Construction

Two Braid Shown

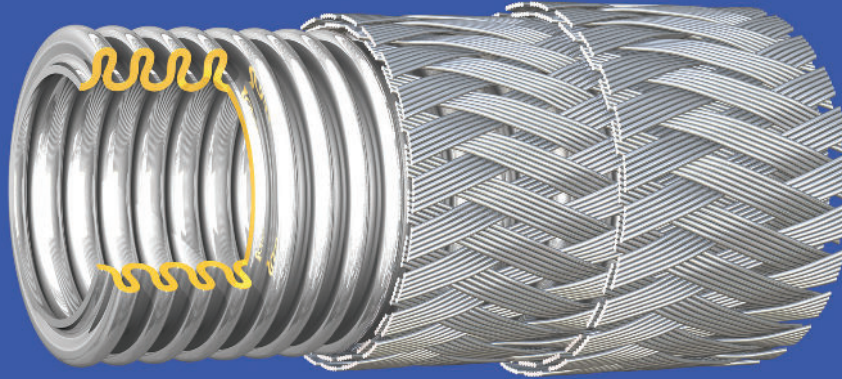

402X

Construction:

T316L stainless steel heavy weight hose
T321 direct double braid
 Annular construction
 For ultra high pressure and hydraulic applications

Sizes:

1/4" through 2"

Maximum Working Pressure:

Full vacuum up to 5300 psig depending on size

Temperature:

Cryogenic to 1500°F

NOMINAL HOSE I.D.	HOSE TYPE	HOSE O.D.	WEIGHT PER FT.	MIN.LIVE LENGTH FOR VIBRATION	MINIMUM BEND RADIUS		MAXIMUM WORKING PRESSURE	MAXIMUM TEST PRESSURE	NORMAL BURST PRESSURE
					STATIC BEND	DYNAMIC FLEXING			
1/4"	402X	0.63	0.39	4.25	2.00	8.250	5300	7950	21200
3/8"	402X	0.81	0.53	5.00	2.50	9.000	3900	5850	15600
1/2"	402X	1.05	0.75	6.00	3.00	10.500	3600	5400	14400
3/4"	402X	1.43	1.63	7.00	4.00	12.750	3550	5325	14200
1"	402X	1.75	2.07	8.25	5.25	15.000	2800	4200	11200
1 1/4"	402X	2.08	2.93	9.00	6.50	17.250	2480	3720	9920
1 1/2"	402X	2.41	3.62	10.00	8.00	19.500	2200	3300	8800
2"	402X	3.05	4.63	12.00	11.50	24.000	1675	2512	6700

403XM – T321 Ultra Heavy Hose with Special Tri Stainless Steel Braids

NOMINAL HOSE I.D.	HOSE TYPE	HOSE O.D.	WEIGHT PER FT.	MIN.LIVE LENGTH FOR VIBRATION	MINIMUM BEND RADIUS		MAXIMUM WORKING PRESSURE	MAXIMUM TEST PRESSURE	NORMAL BURST PRESSURE
					STATIC BEND	DYNAMIC FLEXING			
3"	403XM	3.94	5.47	15.00	25.00	TBA	1200	1800	4800

403XM-I – NEW PRODUCT

Inconel® 625 Ultra Heavy Hose with Special Tri Stainless Steel Braids

NOMINAL HOSE I.D.	HOSE TYPE	HOSE O.D.	WEIGHT PER FT.	MIN.LIVE LENGTH FOR VIBRATION	MINIMUM BEND RADIUS		MAXIMUM WORKING PRESSURE	MAXIMUM TEST PRESSURE	NORMAL BURST PRESSURE
					STATIC BEND	DYNAMIC FLEXING			
3"	403XM-I	3.99	6.88	15.75	25.00	TBA	1800	2700	7200

404XM – T321 Ultra Heavy Hose with Special Quad Stainless Steel Braids

NOMINAL HOSE I.D.	HOSE TYPE	HOSE O.D.	WEIGHT PER FT.	MIN.LIVE LENGTH FOR VIBRATION	MINIMUM BEND RADIUS		MAXIMUM WORKING PRESSURE	MAXIMUM TEST PRESSURE	NORMAL BURST PRESSURE
					STATIC BEND	DYNAMIC FLEXING			
4"	404XM	5.20	9.19	17.00	33.00	114.000	1200	1800	4800

Helical Hose
Construction

Multi Braid Layers

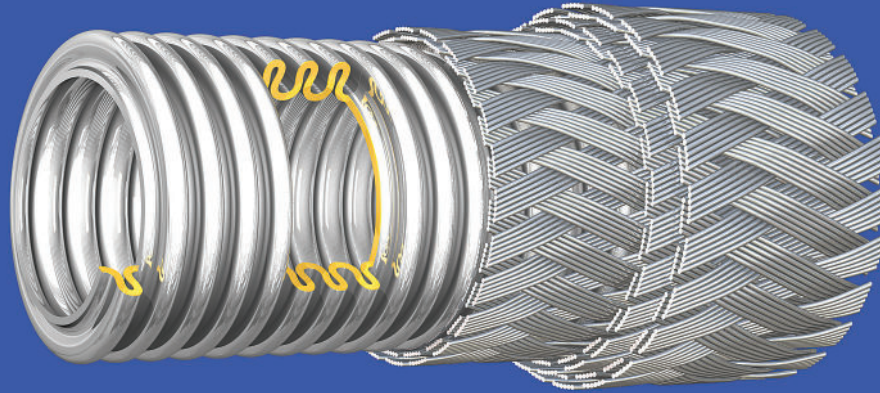

RF67-XFC

Construction:

Ultra Heavy **T321** hose with multi stainless steel braid layers
Helical construction
For ultra high pressure applications

Sizes:

1/4" through 3"

Maximum Working Pressure:

Full vacuum up to 12000 psig
depending on size

Temperature:

Cryogenic to 1500°F

NOMINAL HOSE I.D.	HOSE TYPE	HOSE O.D.	WEIGHT PER FT.	MIN.LIVE LENGTH FOR VIBRATION	MINIMUM BEND RADIUS		MAXIMUM WORKING PRESSURE	MAXIMUM TEST PRESSURE	NORMAL BURST PRESSURE
					STATIC BEND	DYNAMIC FLEXING			
1/4"	RF67-XFC	0.68	0.62	6.00	2.500	11.500	12000	18000	48000
3/8"	RF67-XFC	0.90	0.97	7.00	3.750	15.000	9000	13500	36000
1/2"	RF67-XFC	1.04	1.34	8.00	4.500	16.500	8500	12750	34000
3/4"	RF67-XFC	1.52	2.56	9.00	6.500	30.500	6800	10200	27200
1"	RF67-XFC	1.93	3.69	10.00	9.000	35.000	6250	9375	25000
1 1/4"	RF67-XFC	2.15	5.08	12.00	10.000	38.000	5500	8250	22000
1 1/2"	RF67-XFC	2.54	6.63	14.00	12.000	41.000	5200	7800	20800
2"	RF67-XFC	3.04	8.07	18.00	15.000	48.000	4350	6525	17400
3"	RF67-XFC	4.06	14.81	24.00	25.000	65.000	3000	4500	12000

Consult US Hose Corp Engineering team for pressure rating support
Pressure rating achieved in controlled environment with custom fittings
Actual pressure rating is Dependant on fittings and other aspects of the application.

AFCX

Construction:

T321 and **T316L** stainless steel hose
Series 300 stainless steel braid
 Annular construction

Sizes:

Direct braided on reels - up to 500 feet

Maximum Working Pressure:

Full vacuum to 1825 psig
 depending on use

Temperature:

Cryogenic to 1250° F

NOMINAL HOSE I.D.	HOSE TYPE	HOSE O.D.	WEIGHT PER FT.	MIN.LIVE LENGTH FOR VIBRATION	MINIMUM BEND RADIUS		MAXIMUM WORKING PRESSURE	MAXIMUM TEST PRESSURE	NORMAL BURST PRESSURE
					STATIC BEND	DYNAMIC FLEXING			
1/4"	USCX0	0.38	0.08	3.50	0.591	3.150	145	218	—
	USCX1	0.43	0.09	3.50	0.984	3.150	1825	2738	7300
3/8"	USCX0	0.56	0.11	4.50	0.709	5.039	80	120	—
	USCX1	0.61	0.20	4.50	1.496	5.039	1350	2025	5400
1/2"	USCX0	0.79	0.18	4.75	0.905	5.728	80	120	—
	USCX1	0.84	0.27	4.75	2.022	5.728	1200	1800	4800
3/4"	USCX0	1.06	0.26	5.25	1.260	6.614	60	90	—
	USCX1	1.11	0.27	5.25	2.756	6.614	875	1313	3500
1"	USCX0	1.27	0.35	5.50	1.575	7.480	60	90	—
	USCX1	1.34	0.63	6.50	3.346	7.480	900	1350	3600
1 1/4"	USCX0	1.62	0.44	7.50	1.969	10.039	50	75	—
	USCX1	1.67	0.68	7.50	4.134	10.039	515	773	2060
	USCX2	1.72	0.92	7.50	4.134	10.039	800	1200	3200
1 1/2"	USCX0	1.96	0.71	8.00	2.362	11.614	36	54	—
	USCX1	2.03	1.09	8.00	5.118	11.614	435	653	1740
	USCX2	2.10	1.47	8.00	5.118	11.614	800	1200	3200
2"	USCX0	2.38	0.90	9.50	2.756	12.598	15	23	—
	USCX1	2.44	1.36	9.50	6.299	12.598	425	638	1700
	USCX2	2.50	1.82	9.50	6.299	12.598	600	900	2400

280X/286X

Construction:

T321 (280X) or **T316L (286X)** hose
Series 300 stainless steel braid
 Helical construction

Sizes:

1/4" through 1-1/2"

Maximum Working Pressure:

Full vacuum to 2240 psig
 depending on use

Temperature:

Cryogenic to 1500° F

NOMINAL HOSE I.D.	HOSE TYPE	HOSE O.D.	WEIGHT PER FT.	MIN.LIVE LENGTH FOR VIBRATION	MINIMUM BEND RADIUS		MAXIMUM WORKING PRESSURE	MAXIMUM TEST PRESSURE	NORMAL BURST PRESSURE
					STATIC BEND	DYNAMIC FLEXING			
1/4"	280	0.44	0.12	4.50	0.625	3.500	75	113	—
	281	0.51	0.18	4.50	0.625	3.500	2240	3360	8960
3/8"	280	0.59	0.16	5.50	0.825	4.000	50	75	—
	281	0.65	0.24	5.50	0.825	4.000	1374	2061	5496
1/2"	280	0.77	0.21	6.50	1.125	5.500	50	75	—
	281	0.83	0.30	6.50	1.125	5.500	1028	1542	4112
3/4"	280	1.07	0.41	7.00	1.500	6.000	30	45	—
	281	1.13	0.54	7.00	1.500	6.000	598	897	2392
1"	280	1.40	0.55	7.50	2.000	7.000	25	38	—
	281	1.46	0.73	7.50	2.000	7.000	567	851	2268
1 1/4"	280	1.73	0.91	9.00	2.500	11.500	20	30	—
	281	1.79	1.11	9.00	2.500	11.500	447	671	1788
1 1/2"	280	2.07	1.10	9.00	3.000	14.000	15	23	—
	281	2.13	1.36	9.00	3.000	14.000	392	588	1568

Monel® 400

Construction:

Monel® 400 hose and braid
Annular construction

Maximum Working Pressure:

Full vacuum up to 3025 psig
depending on size

Sizes:

1/2" through 3"

Temperature:

Cryogenic to 800°F

500 Unbraided
502 Two Braid

501 One Braid

NOMINAL HOSE I.D.	HOSE TYPE	HOSE O.D.	WEIGHT PER FT.	MIN.LIVE LENGTH FOR VIBRATION	MINIMUM BEND RADIUS		MAXIMUM WORKING PRESSURE	MAXIMUM TEST PRESSURE	NORMAL BURST PRESSURE
					STATIC BEND	DYNAMIC FLEXING			
1/4"	500	0.49	0.16	3.75	0.875	5.500	180	270	—
	501	0.55	0.23	3.75	0.875	5.500	2250	3375	9000
	502	0.61	0.31	3.75	0.875	5.500	3025	4535	12100
3/8"	500	0.66	0.24	4.50	1.125	6.000	140	210	—
	501	0.73	0.34	4.50	1.125	6.000	1575	2360	6300
	502	0.79	0.44	4.50	1.125	6.000	2050	3075	8200
1/2"	500	0.84	0.40	5.00	1.500	7.000	120	180	—
	501	0.90	0.51	5.00	1.500	7.000	835	1250	3340
	502	0.96	0.64	5.00	1.500	7.000	1500	2250	6000
3/4"	500	1.21	0.79	5.75	2.125	8.500	90	135	—
	501	1.27	0.96	5.75	2.125	8.500	600	900	2400
	502	1.33	1.15	5.75	2.125	8.500	1080	1620	4320
1"	500	1.53	1.02	7.00	2.750	10.000	56	85	—
	501	1.59	1.22	7.00	2.750	10.000	420	630	1680
	502	1.65	1.44	7.00	2.750	10.000	755	1130	3025
1 1/4"	500	1.86	1.61	7.50	3.250	11.500	53	80	—
	501	1.92	1.84	7.50	3.250	11.500	315	420	1270
	502	1.98	2.08	7.50	3.250	11.500	570	855	2285
1 1/2"	500	2.19	1.97	8.00	3.750	13.000	37	55	—
	501	2.29	2.55	8.00	3.750	13.000	565	850	2260
	502	2.39	3.16	8.00	3.750	13.000	1015	1526	4060
2"	500	2.83	2.63	9.50	5.000	16.000	20	30	—
	501	2.93	3.37	9.50	5.000	16.000	415	620	1660
	502	3.03	4.11	9.50	5.000	16.000	745	1015	2985
3"	500	3.57	1.69	9.00	8.250	21.000	4	6	—
	501	3.67	2.50	9.00	8.250	21.000	225	335	900
	502	3.77	3.32	9.00	8.250	21.000	425	635	1700

Monel® Slip-On Braid Specifications

TYPICAL HOSE O.D. (IN.)	NOMINAL HOSE I.D. (IN.)	BRAID I.D. (IN.)	BRAID CONSTRUCTION	BRAID ANGLE	COVERAGE (%)	WORKING PRESSURE (PSIG)	WEIGHT (LB/FT)
0.49	1/4	0.48	24x5x.0126	52	84.0	1665	0.07
0.66	3/8	0.66	24x7x.0126	52	86.1	1160	0.10
0.84	1/2	0.84	24x8x.0126	52	80.8	830	0.12
1.21	3/4	1.20	48x6x.0126	52	83.7	605	0.17
1.53	1	1.53	48x8x.0126	52	86.2	415	0.23
1.86	1 1/4	1.86	48x10x.0126	52	97.6	315	0.29
2.19	1 1/2	2.19	48x8x.020	52	90.8	570	0.58
2.83	2	2.83	48x10x.020	52	89.5	415	0.73
3.57	3	3.57	48x10x.020	45	94.3	185	0.64

Inconel® 625

Construction:

Inconel® 625 hose
T321 braid (Inconel braid also available)
Annular construction

Maximum Working Pressure:

Full vacuum up to 2660 psig depending on size and braid construction

Sizes:

1/4" through 4"

Temperature:

Cryogenic to 1500°F with T321 braid
Cryogenic to 1800°F with Inconel braid

INC00 Unbraided

INC01 Single Braid

* **Contact factory for other grades**

NOMINAL HOSE I.D.	HOSE TYPE	HOSE O.D.	WEIGHT PER FT.	MIN.LIVE LENGTH FOR VIBRATION	MINIMUM BEND RADIUS		MAXIMUM WORKING PRESSURE	MAXIMUM TEST PRESSURE	NORMAL BURST PRESSURE
					STATIC BEND	DYNAMIC FLEXING			
1/4"	INC00	0.49	0.11	3.50	0.875	5.000	228	342	
	INC01	0.55	0.18	3.50	0.875	5.000	2660	3990	10640
3/8"	INC00	0.66	0.15	4.25	1.125	5.500	150	225	
	INC01	0.73	0.23	4.25	1.125	5.500	1610	2415	6440
1/2"	INC00	0.84	0.21	4.50	1.500	6.000	79	119	
	INC01	0.90	0.32	4.50	1.500	6.000	1310	1965	5240
3/4"	INC00	1.21	0.34	5.50	2.125	8.000	32	48	
	INC01	1.27	0.50	5.50	2.125	8.000	915	1373	3660
1"	INC00	1.53	0.59	6.50	2.750	9.000	38	57	
	INC01	1.59	0.78	6.50	2.750	9.000	645	968	2580
1 1/4"	INC00	1.86	0.78	7.00	3.250	10.500	22	33	
	INC01	1.92	1.02	7.00	3.250	10.500	545	818	2180
1 1/2"	INC00	2.19	0.93	7.50	3.750	12.000	26	39	
	INC01	2.27	1.27	7.50	3.750	12.000	560	840	2240
2"	INC00	2.72	1.23	7.75	5.000	15.000	14	21	
	INC01	2.80	1.68	7.75	5.000	15.000	460	675	1800
2 1/2"	INC00	3.11	1.08	11.00	7.000	16.000	7	10	
	INC01	3.23	1.87	11.00	7.000	16.000	545	815	2180
3"	INC00	3.57	1.07	9.00	8.250	17.000	5	7.5	
	INC01	3.69	1.93	9.00	8.250	17.000	440	660	1760
4"	INC00	4.72	2.57	10.75	11.000	27.000	4	6	
	INC01	4.84	3.53	10.75	11.000	27.000	270	405	1080

Hastelloy® C276

Construction:

Hastelloy® hose
Series 300 stainless steel or Hastelloy braid
Annular construction

Maximum Working Pressure:

Full vacuum to 1550 psig depending on size and braid construction

Sizes:

1/2" through 2"

Temperature:

Cryogenic to 2000°F with Hastelloy braid
Cryogenic to 1500°F with T321 stainless steel braid

HAS00 Unbraided

HAS01 One Braid

NOMINAL HOSE I.D.	HOSE TYPE	HOSE O.D.	WEIGHT PER FT.	MIN.LIVE LENGTH FOR VIBRATION	MINIMUM BEND RADIUS		MAXIMUM WORKING PRESSURE	MAXIMUM TEST PRESSURE	NORMAL BURST PRESSURE
					STATIC BEND	DYNAMIC FLEXING			
1/2"	HAS00	0.84	0.31	4.50	1.500	6.000	80	120	-
	HAS01	0.90	0.42	4.50	1.500	6.000	1550	2325	6200
3/4"	HAS00	1.21	0.49	5.50	2.130	8.000	70	105	-
	HAS01	1.27	0.67	5.50	2.130	8.000	915	1370	3660
1"	HAS00	1.53	0.80	6.50	2.750	9.000	43	65	-
	HAS01	1.59	0.98	6.50	2.750	9.000	645	965	2580
1 1/4"	HAS00	1.86	1.05	7.00	3.250	10.500	29	42	-
	HAS01	1.92	1.29	7.00	3.250	10.500	575	860	2300
1 1/2"	HAS00	2.19	1.59	7.50	3.750	12.000	31	47	-
	HAS01	2.27	1.97	7.50	3.750	12.000	585	875	2340
2"	HAS00	2.83	2.08	9.00	5.000	15.000	17	26	-
	HAS01	2.91	2.55	9.00	5.000	15.000	470	705	1880

Welded Pipe End with 37-1/2 degree bevel

Size Availability: 1/8" diameter to 12" diameter

Material Availability: Carbon Steel, T304 Stainless Steel, T304L Stainless Steel, T321 Stainless Steel, T316 Stainless Steel, T316L Stainless Steel

Schedule Availability: 5, 10, 40, 80, 160, XX

Note: Not all sizes and schedules are available in combination - consult factory for details

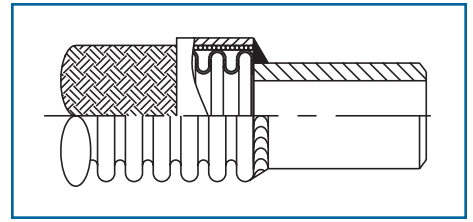

Welded Concentric Reducer

Size Availability: 1/2" diameter to 12" diameter and combinations thereof

Material Availability: Carbon Steel, T304 Stainless Steel, T304L Stainless Steel, T321 Stainless Steel, T316 Stainless Steel, T316L Stainless Steel, Monel 400, Hastelloy, Incoloy, Inconel

Schedule Availability: 5, 10, 40, 80, 160, XX

Note: Not all sizes and schedules are available in combination - consult factory for details

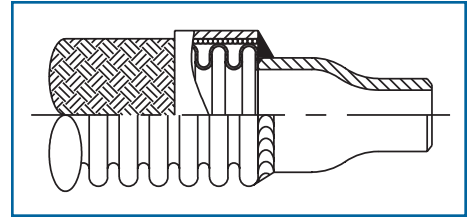

Welded Long Radius 90 Degree Elbow

Size Availability: 1/2" diameter to 12" diameter

Material Availability: Carbon Steel, T304 Stainless Steel, T304L Stainless Steel, T321 Stainless Steel, T316 Stainless Steel, T316L Stainless Steel, Monel 400, Hastelloy, Incoloy, Inconel

Schedule Availability: 5, 10, 40, 80, 160, XX

Note: Not all sizes and schedules are available in combination. Short radius, 45's and other angles are available - consult factory for details

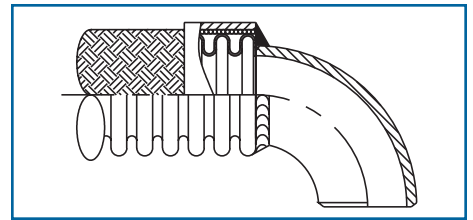

Welded NPT male nipple

Size Availability: 1/8" diameter to 8" diameter

Material Availability: Carbon Steel, T304 Stainless Steel, T304L Stainless Steel, T321 Stainless Steel, T316 Stainless Steel, T316L Stainless Steel

Schedule Availability: 5, 10, 40, 80, 160, XX

Note: Not all sizes and schedules are available in combination - consult factory for details

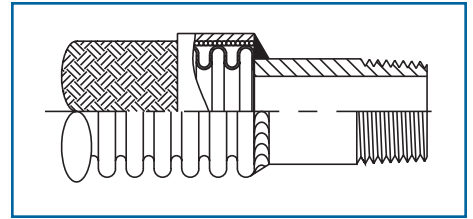

NPT Male Nipple with Integral Hex Nut

Size Availability: 1/4" diameter to 2" diameter

Material Availability: Carbon Steel, T304 Stainless Steel, T304L Stainless Steel, T321 Stainless Steel, T316 Stainless Steel, T316L Stainless Steel, Monel 400, Hastelloy, Incoloy, Inconel

Schedule Availability: 40, 80, 160, XX

Note: Not all sizes, schedules and materials are available in combination - consult factory for details

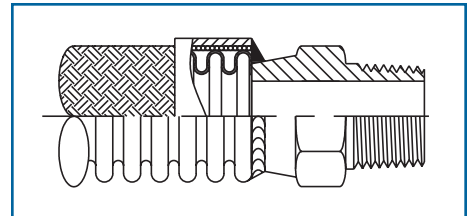

NPT male with welded on Hex Nut

Size Availability: 1/2" diameter to 4" diameter

Material Availability: Carbon Steel, T304 Stainless Steel, T304L Stainless Steel, T321 Stainless Steel, T316 Stainless Steel, T316L Stainless Steel, Monel 400, Hastelloy, Incoloy, Inconel

Manufactured from hexagon bar stock.

Note: Not all sizes, and materials are available in combination - consult factory for details

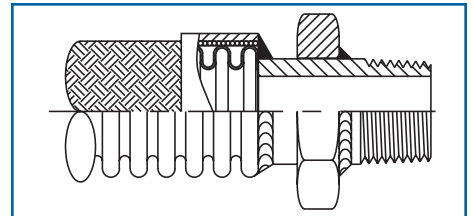

Welded Plate Flange ANSI Class 150 drilling

Size Availability: 1/2" diameter to 12" diameter

Material Availability: Carbon Steel and Stainless Steel

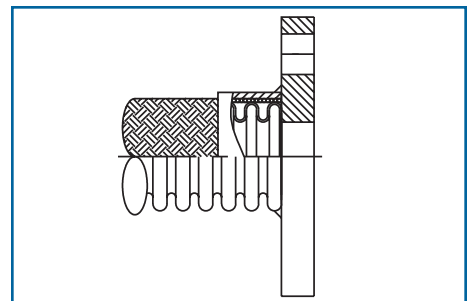

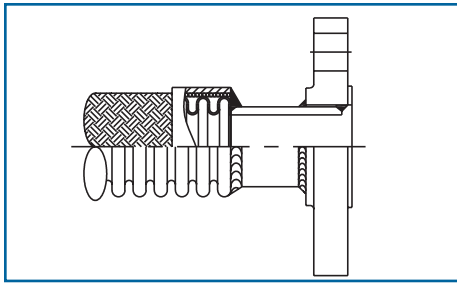

Raised Face Slip-On Flange on Pipe End

Size Availability: 1/2" diameter to 12" diameter

Material Availability: Carbon Steel, T304 Stainless Steel, T304L Stainless Steel, T321 Stainless Steel, T316 Stainless Steel, T316L Stainless Steel, Monel 400, Hastelloy, Inconel

Schedule Availability: 5, 10, 40, 80, 160, XX

ANSI Class Ratings: 150, 300, 600, 900, 1500, 2500

RTJ flanges also available - consult factory for details

Note: Not all sizes and schedules are available in combination - consult factory for details

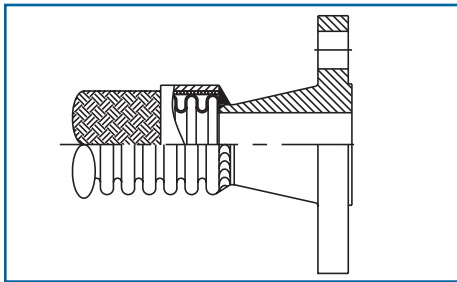

Welded Raised Face Weldneck Flange

Size Availability: 1/2" diameter to 12" diameter

Material Availability: Carbon Steel, T304 Stainless Steel, T304L Stainless Steel, T321 Stainless Steel, T316 Stainless Steel, T316L Stainless Steel, Monel 400, Hastelloy, Incoloy, Inconel

Schedule Availability: 5, 10, 40, 80, 160, XX

ANSI Class Ratings: 150, 300, 600, 900, 1500, 2500

RTJ flanges also available - consult factory for details

Note: Not all sizes and schedules are available in combination - consult factory for details

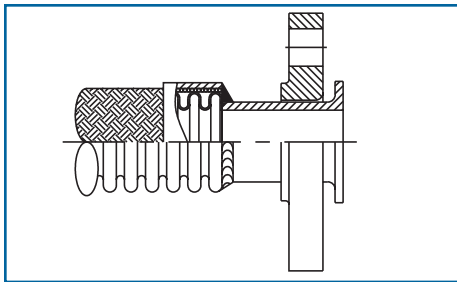

Lap Joint Floating Flange with Type "A" MSS stub end

Size Availability: 1/2" diameter to 12" diameter

Material Availability: Carbon Steel, T304 Stainless Steel, T304L Stainless Steel, T321 Stainless Steel, T316 Stainless Steel, T316L Stainless Steel, Monel 400, Hastelloy, Incoloy, Inconel

Schedule Availability: 5, 10, 40, 80, 160, XX

ANSI Class Ratings: 150, 300, 600, 900, 1500, 2500

Note: Not all sizes and schedules are available in combination.

Type "C" stub ends are also available - consult factory for details.

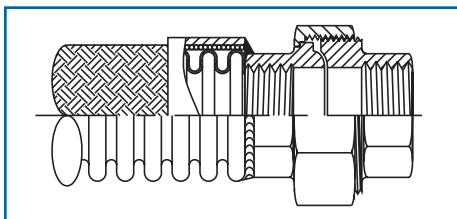

Welded Female Union

Size Availability: 1/2" diameter to 4" diameter

Material Availability: Carbon Steel, T304 Stainless Steel, T304L Stainless Steel, T316 Stainless Steel, T316L Stainless Steel

Pressure: 150, 300, 3000, 6000 pound

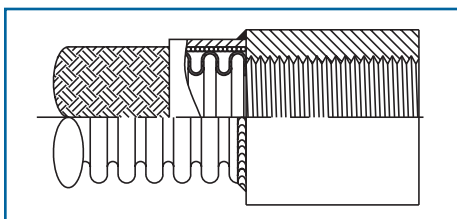

Welded Female NPT Half Pipe Coupling

Size Availability: 1/2" diameter to 4" diameter

Material Availability: Carbon Steel, T304 Stainless Steel, T304L Stainless Steel, T321 Stainless Steel, T316 Stainless Steel, T316L Stainless Steel, Monel 400, Hastalloy, Incoloy, Inconel

Pressure: 150, 300, 3000, 6000 pounds

Note: Not all sizes and Pressures are available in combination.

Female NPT Full Pipe Coupling is also available - consult factory for details

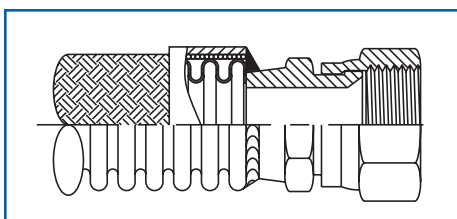

Welded JIC Swivel Female

Size Availability: 1/4" diameter to 2" diameter

Material Availability: Carbon Steel & T316 Stainless Steel

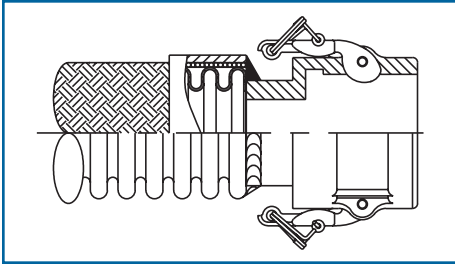

Welded Quick Disconnect Female Part "D" Coupler

Size Availability: 1/2" diameter to 8" diameter

Material Availability: Carbon Steel & T316 Stainless Steel, Hastelloy
 - Other materials are available - consult factory for details

Note: Not all sizes and materials are available in combination - consult factory for details

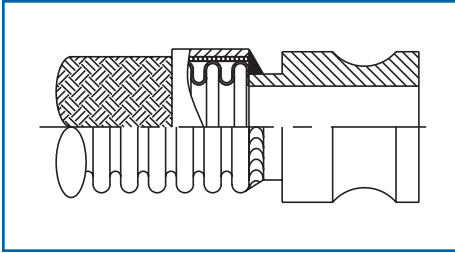

Welded Quick Disconnect Male Part "A" Camlock

Size Availability: 1/2" diameter to 8" diameter

Material Availability: Steel, T316 Stainless Steel and Hastelloy
 - other materials available - consult factory for details

Note: Not all sizes and materials are available in combination - consult factory for details

Helical Hose Construction in Profile with Single Layer of Braid

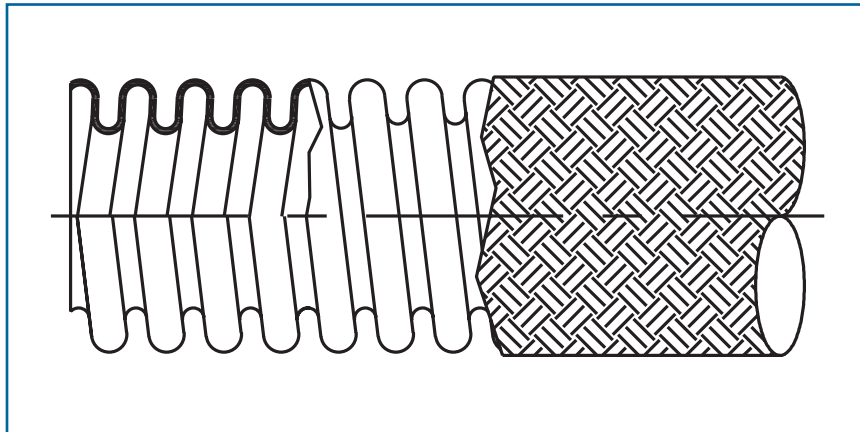

Annular Hose Construction in Profile With Single Braid

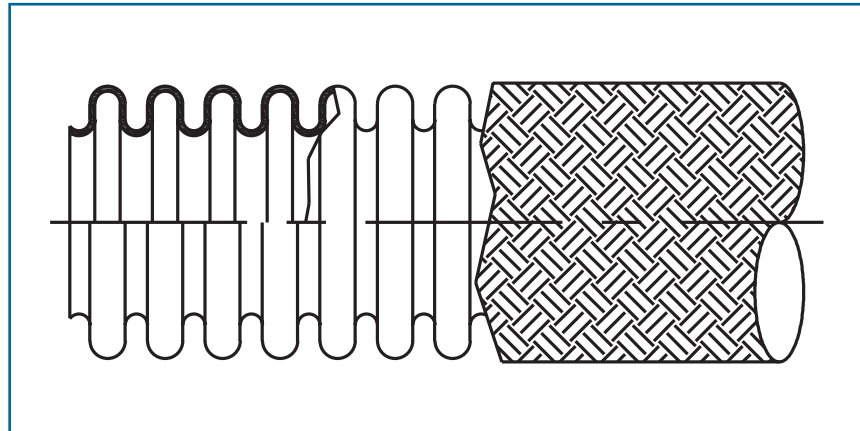

I. PRESSURE

US Hose pressure ratings are in accordance with industry-wide good practice and are consistent with the requirements of the USA Standard Code for Pressure Piping and the ASME Boiler and Pressure Vessel Code, Sec. VIII.

Maximum Working Pressure

Maximum operating pressure to which the hose should be subjected. It is established at 25% of the Nominal Design Burst Pressure. The hose may be deflected within the specified bend radius range.

Maximum Proof Pressure

Maximum test pressure to which the hose should be subject. It is established at 150% of the Maximum Working Pressure with the hose installed straight. No harmful deformation shall occur.

Hydrostatic field tests of hose assemblies installed in varying degrees of radial bend or parallel offset should be limited to 120% of the maximum rated working pressure at 70°F, or 150% of the actual operating pressure, whichever is lower.

Nominal Design Burst Pressure

The pressure at which the hose can be expected to rupture, based on the minimum annealed ultimate tensile strength of the braid wire and corrugated hose alloys at 70°F and the hose installed straight.

Pulsating or Shock Pressures

When pulsating, surge or shock pressures exists, such as occur due to fast closing valves, the peak pressure shall not exceed 50% of the Maximum Working Pressure. Installation shall be such that there is no initial slack in the braid when the pressure pulse, surge or shock occurs.

Pressure Relative To Unbraided Hose

At Maximum Working Pressure, 1 to 2 1/2% elastic elongation will occur in unbraided hose assemblies. To avoid squirm, unbraided hose should be unrestrained at one end, or installed in such a manner as to allow free axial expansion due to pressure, as in a 180° loop.

Pressure Relative To Braided Hose

Whenever appreciable internal pressure is applied to a corrugated metal hose, it will elongate unless restrained. Generally this restraint is provided by a wire braid sheath over the hose. The braid has little effect on bending or flexibility of the hose. However, in extremely short lengths of braided and pressurized hose, additional bending forces are required because of braid friction.

Where the strength of the braid sheath is the limiting factor, additional working pressure may be gained by using a heavier than standard single braid, or two or more braids. However, when the hoop rupture strength of the corrugated hose is the limiting factor, no additional pressure resistance is gained with additional braids.

Contact US Hose Engineering Group for braid/hose design assistance to determine maximum pressure ratings at lowest total cost for an application.

Pressure Relative To Temperature

For operating temperatures in excess of 70°F, the tabulated pressures must be decreased in accordance with the "Conversion Factors" listed in the table below. Since the pressure ratings are based on annealed material properties, no reduction in pressure ratings is necessary for fitting attachment by TIG welding, brazing, or soft solder.

Conversion Factors

Apply to pressure rating for elevated temperatures.

TEMPERATURE		MATERIAL				
C°	F°	STAINLESS STEEL	STEEL	MONEL	BRONZE	INCONEL
20	70	1.00	1.00	1.00	1.00	1.00
66	150	0.97	0.99	0.93	0.92	0.97
93	200	0.94	0.97	0.90	0.89	0.94
121	250	0.92	0.96	0.87	0.86	0.92
150	300	0.88	0.93	0.83	0.83	0.88
177	350	0.86	0.91	0.82	0.81	0.86
200	400	0.83	0.87	0.79	0.78	0.83
232	450	0.81	0.86	0.77	0.75	0.81
260	500	0.78	0.81	0.73	---	0.78
316	600	0.74	0.74	0.72	---	0.74
371	700	0.70	0.66	0.71	---	0.70
427	800	0.66	0.52	0.70	---	0.66
482	900	0.62	0.50	---	---	0.62
538	1000	0.60	---	---	---	0.60
593	1100	0.58	---	---	---	0.58
649	1200	0.55	---	---	---	0.55
704	1300	0.50	---	---	---	0.50
760	1400	0.44	---	---	---	0.44
815	1500	0.40	---	---	---	0.40
982	1800	0.40	---	---	---	0.40

Consult US Hose Engineering Group whenever service conditions necessitate consideration of the influence of long time exposure at elevated temperature. Consult factory for maximum temperature of Hastelloy materials.

II. MAXIMUM SERVICE TEMPERATURE OF MATERIAL

Maximum Service Temperature

ALLOY	MAXIMUM TEMP. °F.	ALLOY	MAXIMUM TEMP. °F.
Hastelloy® C-276	2000		
Inconel® 625	1800	Brazing (RCuZn-C or BCuP-2)	
AISI Stainless Steel Type:		Bronze Hose	450
321	1500		
316 ELC	1500	Silver Brazing	
304L	1500	(AWS-BAG-2)	600
304	850		
302	850	Aluminum 52S-0 (5052-0)	600
Mild Steel	850	Galvanizing	450
Malleable Iron	800	Soft Solder (Pb: 60, Sn: 40)	250
Monel®	800	(Pb: 95, Sn: 5)	350
Bronze	450	Silicone Coated Fiberglass	600
Brass	450	Aluminized Fiberglass	1000
Copper	400		

Consult US Hose Engineering Group whenever service conditions necessitate consideration of the influence of long time exposure at elevated temperature.

III. FLOW VELOCITY

- 1) Where flow velocity exceeds 100 ft/sec gas (50 ft/sec liquid), in unbraided hose, or 150 ft/sec gas (75 ft/sec liquid), in braided hose, a flexible metal liner of fully interlocked (RT) hose should be used. When the hose is installed in a bent condition, these flow values should be reduced by 50% for a 90° bend, 25% for a 45° bend, and so on, proportional to the angle of bend. In cases where velocity exceeds the above values, the next larger size corrugated hose should be used with the flexible RT liner size equivalent to the mating pipe size.
- 2) Where the amount of pressure drop through longer lengths of hose is a significant factor, a larger diameter hose may be required. As a broad rule of thumb, pressure drop through a corrugated metal hose is approximately three times that in comparable size standard steel pipe. For more accurate calculations of pressure drop, consult US Hose Engineering Group.

IV. MOTION

Most industrial applications can be reduced to one of five classes of motion: 1) **Angular**; 2) **Axial**; 3) **Offset**; 4) **Radial**; or 5) **Random**.

1. Angular Motion:

Motion that occurs when one end of a hose assembly is deflected in a simple bend with the ends not remaining parallel. Angular motion may be incorporated in an installation to accommodate misalignment and vibration only, but must not be used to accommodate expansion that would result in unloading the braid.

2. Axial Motion:

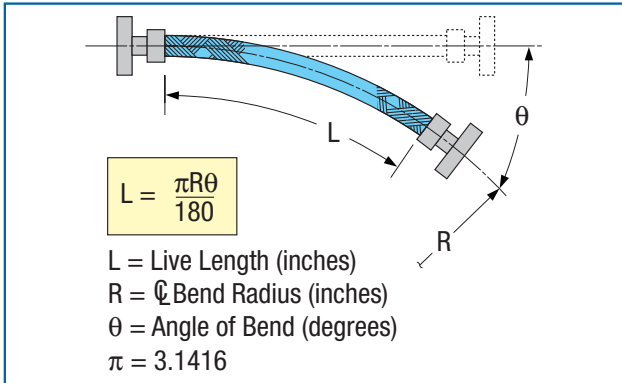

This type of motion occurs when one end of a hose assembly is deflected along its longitudinal axis. Axial motion is applicable to annular corrugated, unbraid flexible hose only. Neither helical hose nor braided hose should be used in axial motion applications.

3. Offset Motion:

Motion that occurs when one end of the hose assembly is deflected in a plane perpendicular to the longitudinal axis with the end remaining parallel. Offset is measured in inches of displacement of the free end center line from the fixed end center line. In offset motion applications, the offset should never be greater than one-fourth (25%) of the minimum center line bend radius.

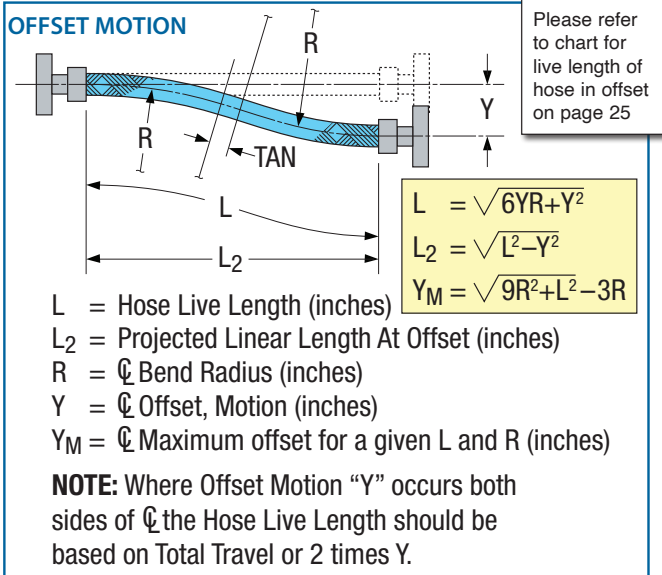

4. Radial Motion:

This type of motion occurs when the center line of a hose assembly is bent in a circular arc. In industrial applications, radial motion is most commonly found in traveling loops.

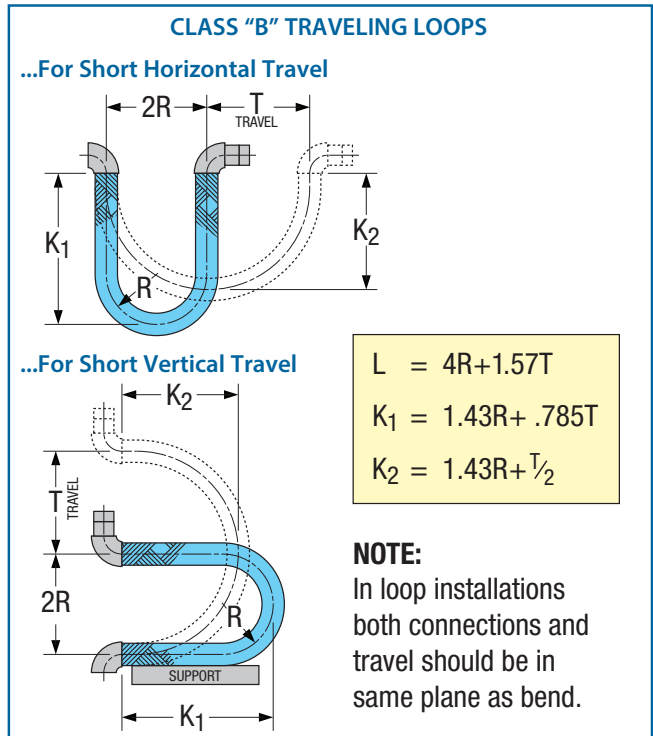
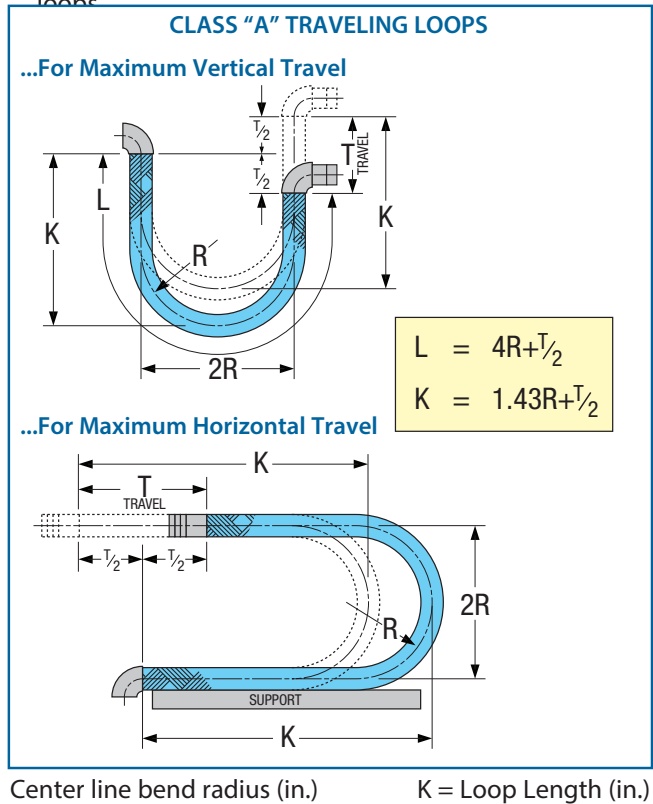

5. Random Motion:

Non-predictable motion that occurs from manual handling of an assembly. Loading and unloading hose would generally fall into this category. Abusive handling of hose is an important factor to consider in applications involving random motions. The use of an interlocked (RT-6) guard over the corrugated hose is recommended to protect the hose assembly from rough handling and “over-bending” adjacent to the fittings.

V. MOTION FREQUENCY

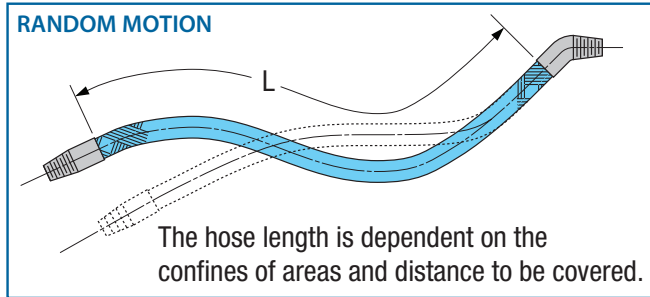

The frequency of a particular class of motion to which a flexible metal hose may be subjected by repeated flexing or bending. The frequency of motion may be divided into three basic categories: namely vibration, dynamic, and continuous. The minimum live length required for these motion categories may be selected as follows:

1. Vibration:

For the normal vibration encountered in industrial applications, such as pump and compressor discharge lines and engine exhaust installations, the hose live lengths should be taken from the Minimum Live Length For Vibration column on Technical Data Pages.

Normal vibration is shown as the unshaded area of the chart below. If the expected combination of double amplitude (total motion excursion) and frequency falls into the shaded area, consult US Hose Engineering Group.

Caution: Avoid hose resonance. If resonance is anticipated, consult US Hose Engineering Group.

2. Dynamic Motion:

Motion that occurs on a regular or irregular basis normally the result of thermal expansion and contraction or other noncontinuous actions.

The dynamic flexing bend radius shown on Hose Technical Data Pages shall be used in the formulas for angular, radial and offset motion when determining hose live length for dynamic motion.

3. Continuous Motion:

Motion that occurs on a regular cyclic basis normally at a slow cyclic rate and constant travel. For Continuous Lateral Offset Motion double the minimum centerline bend radius for Dynamic Flexing shown on Hose Technical Data Pages.

4. Static Bend:

The minimum center line bend radius to which a flexible metal hose may be bent for installation. No further motion is to be imposed other than normal vibration.

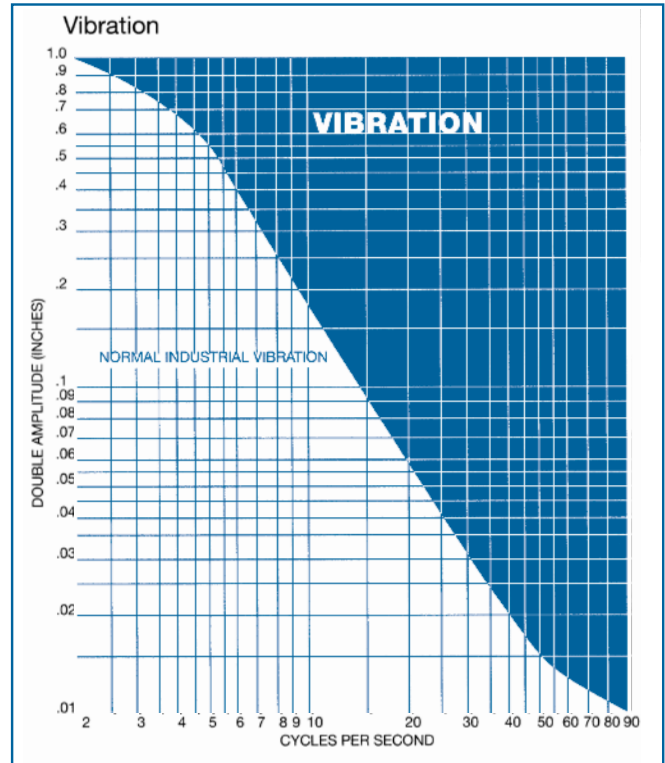

VI. CYCLE LIFE

The cycle life expectancy of a metal hose is affected by various factors such as: operating pressure, operating temperature, materials, bend radius (the movement per corrugation due to the flexure), the thickness of the corrugation. Any change in one of these factors will result in a change in the cycle life of a metal hose assembly.

The cycle life of a metal hose assembly is proportional to the sum of the pressure stress range and deflection stress range. The life expectancy can be defined as the total number of completed cycles which can be expected from the metal hose assembly based on S/N curves and data tabulated from tests performed under simulated operating conditions. A cycle is defined as one complete movement from the initial position in the system to some operating point and returning to the original position.

This information should be used as a guide only. We cannot predict every variable which might be encountered in every application nor any misapplication, mechanical damage, and/or any uncontrollable situation.

Chart for Live Length of Hose in Offset

CenterLine

Radius

Inches*Dynamic Offset Motion • Maximum Distance from Centerline • See Sketch, Page 24

	1/8"	1/4"	3/8"	1/2"	3/4"	1"	1 1/2"	2"	3"	4"	5"	6"	8"	10"
2	1 1/4	1 3/4	2 1/4	2 1/2	3 1/4	3 3/4	4 1/4	5 1/4	6 3/4	8	9 1/4	10 1/2	11 3/4	15
4	1 3/4	2 1/2	3	3 1/2	4 1/2	5	6 1/4	7 1/4	9	10 3/4	12	13 1/2	16	18 1/2
6	2 1/4	3 1/4	3 3/4	4 1/4	5 1/4	6 1/4	7 1/2	8 3/4	10 3/4	12 3/4	14 1/4	16	19	21 1/2
8	2 1/2	3 1/2	4 1/4	5	6	7	8 3/4	10	12 1/2	14 1/2	16 1/4	18	21 1/4	24 1/4
10	2 3/4	4	4 3/4	5 1/2	6 3/4	8	9 3/4	11 1/4	13 3/4	16	18	20	23 1/2	26 1/2
12	3	4 1/4	5 1/4	6	7 1/2	8 1/2	10 1/2	12 1/4	15	17 1/2	19 1/2	21 1/2	25 1/2	28 3/4
14	3 1/4	4 3/4	5 3/4	6 1/2	8	9 1/4	11 1/4	13 3/4	16 1/4	18 3/4	21	23 1/2	27 1/4	30 3/4
16	3 1/2	5	6	7	8 1/2	10	12 1/4	14	17 1/4	20	22 1/2	25	29	32 3/4
18	3 3/4	5 1/4	6 1/2	7 1/2	9	10 1/2	13	15	18 1/4	21 1/4	24	26	30 1/2	34
20	4	5 1/2	6 3/4	7 3/4	9 1/2	11	13 1/2	15 3/4	19 1/4	22 1/2	25	27 1/2	32 1/4	36 1/4
25	4 1/2	6 1/4	7 1/2	8 3/4	10 3/4	12 1/4	15	17 1/2	21 1/2	25	28	30 1/2	35 1/4	40
30	4 3/4	6 3/4	8 1/4	9 1/2	11 3/4	13 1/2	16 1/2	19	23 1/2	27 1/4	30 1/2	33 1/2	39	43 3/4
35	5 1/4	7 1/4	9	10 1/4	12 1/2	14 1/2	18	20 3/4	26 1/4	29 1/2	32 3/4	36	42	47
40	5 1/2	7 3/4	9 1/2	11	13 1/2	15 1/2	19	22	27	31 1/4	35	38 1/2	44 3/4	50
45	6	8 1/4	10	11 3/4	14 1/4	16 1/2	20 3/4	23 1/2	28 1/2	33 1/4	37	41	47 1/2	53
50	6 1/4	8 3/4	10 3/4	12 1/4	15	17 1/2	21 1/4	24 1/2	30	35	39	43	50	56
60	6 3/4	9 1/2	11 3/4	13 1/2	16 1/2	19	23 1/4	27	33	38 1/4	43	47	54 1/4	61
70	7 1/4	10 1/4	12 3/4	14 3/4	17 3/4	20 1/2	25 1/4	29	35 1/2	41 1/2	46	51	58 3/4	65 3/4
80	7 3/4	11	13 1/2	15 1/2	19	22	27	31	38	44	49 1/2	54	62 3/4	70
90	8 1/4	11 3/4	14 1/4	16 1/2	20 1/4	23 1/2	28 1/2	33	40 1/2	46 3/4	52	57 1/4	66 1/4	74 1/4
100	8 3/4	12 1/4	15	17 1/2	21 1/4	24 1/2	30	35	42 1/2	49 1/4	55	60 1/2	69 1/4	78 1/4
110	9 1/4	13	15 3/4	18 3/4	22 1/2	25 3/4	31 3/4	36 1/2	44 3/4	51 1/2	58	63 1/4	73 1/4	82
120	9 1/2	13 1/2	16 1/2	19	23 1/4	27	33	38 1/4	46 3/4	54	60 1/2	66	76 1/2	85 1/2
130	10	14	17 1/4	20	24 1/4	28	34 3/4	39 3/4	48 1/2	56	62 3/4	68 3/4	79 1/2	89

*Refer to hose technical pages

IMPORTANT NOTE:

The values shown are minimum live lengths for most centerline bend radii and total offset travel combinations. If the exact radius or travel are not shown on the chart, then the next larger value may be used or use the lateral offset formula. The values as shown in the shaded portion are applicable to static bends only. The offset motion should never be greater than 1/4 (25%) of the centerline bend radius.

Assembly Length (Live Length and Over-all Length)

After the hose is selected for the application, the live length and over-all length of the assembly must be determined to complete the design. The live length is the flexible portion of an assembly and can be determined for the class of motion from the diagrams and for vibration.

After the live length has been determined, the overall length is calculated by adding the dimensions for the end fittings. Refer to factory for fitting lengths as standard and special lengths can be offered.

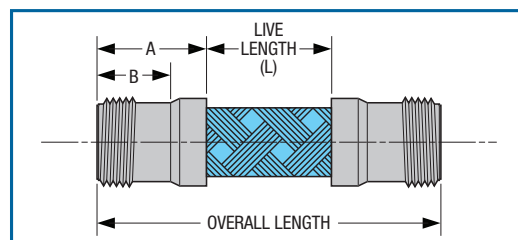

INSTALLATION RULES

Installation Hints

To obtain maximum service life from metal hose, two **IMPORTANT** installation rules must be kept in mind:

1) Do Not Torque

A hose is subject to torque by:

A) Twisting in installation. To minimize possible torque damage to a hose, a union or floating flange should be used at one end of the hose assembly. Where flanges are used, the fixed flange end should be bolted into place before the floating flange end. Where a threaded nipple and a union are used, the nipple end should be threaded into place, and then the union tightened into place using two wrenches.

B) Twisting on flexure. Always install the hose so that flexing takes place in one plane only, and in the plane of bending.

2) Avoid Sharp Bends

There are many ways a hose can be subjected to recurring sharp bends as a result of improper installation. A few examples are illustrated below. The minimum centerline bend radius for dynamic flexing should never be less than the values specified in the Technical Data Section.

Should piping restrictions make it impractical to install hose in the proper manner, the use of interlocked hose guard will limit the hose bending to a suitable radius, thus prolonging the life of the corrugated hose.

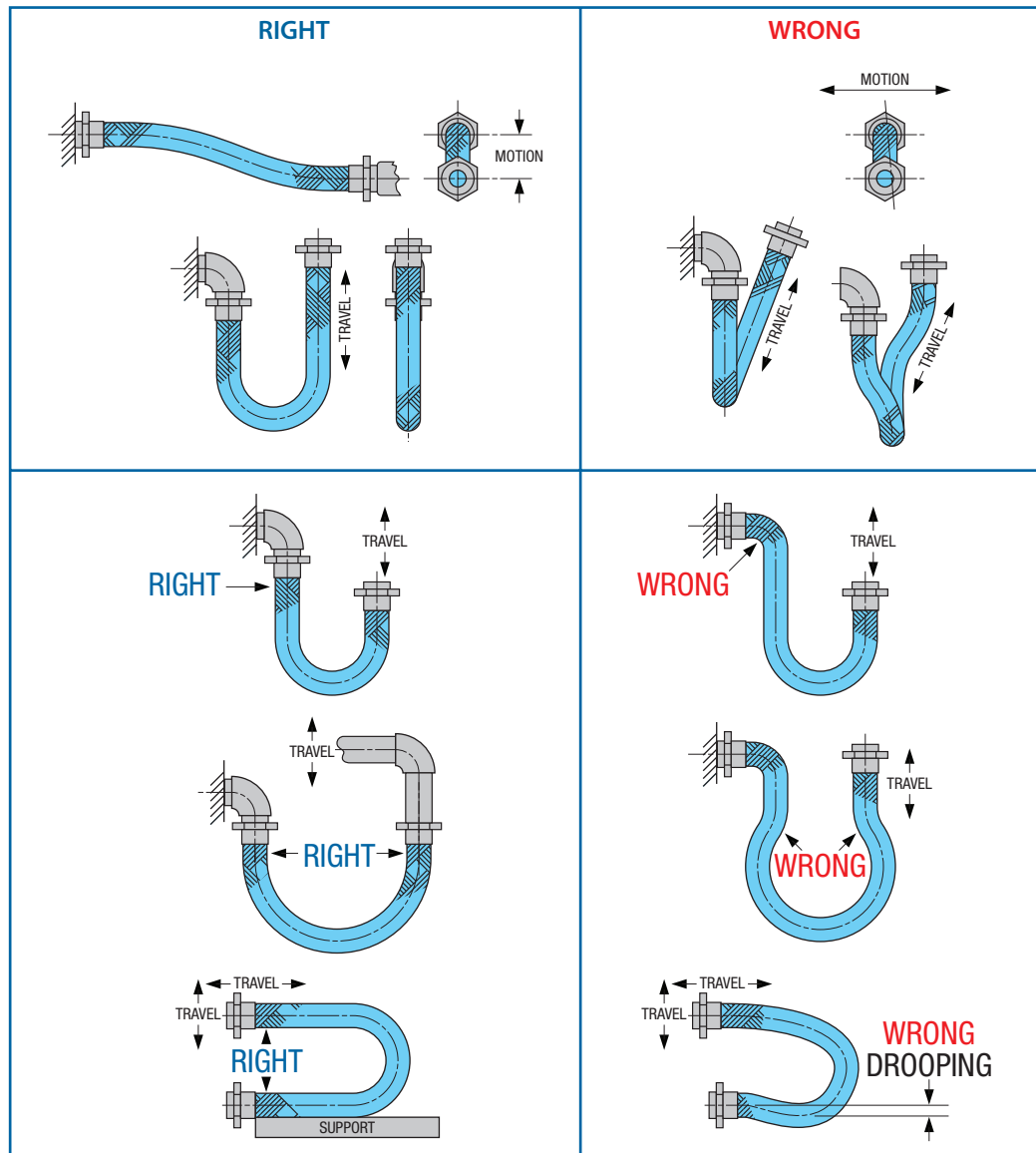

A piping system which utilizes flexible metal hose to absorb pipe movement must be properly anchored and guided to assure correct functioning and maximum service life of the metal hose. The basic principles to be observed are:

1) The direction of pipe motion must be perpendicular to the center line (axis) of the hose.

2) The pipe must be anchored at each change of direction where a flexible metal hose is employed to prevent torsional stress.

Typical examples of correct and incorrect guiding are shown below.

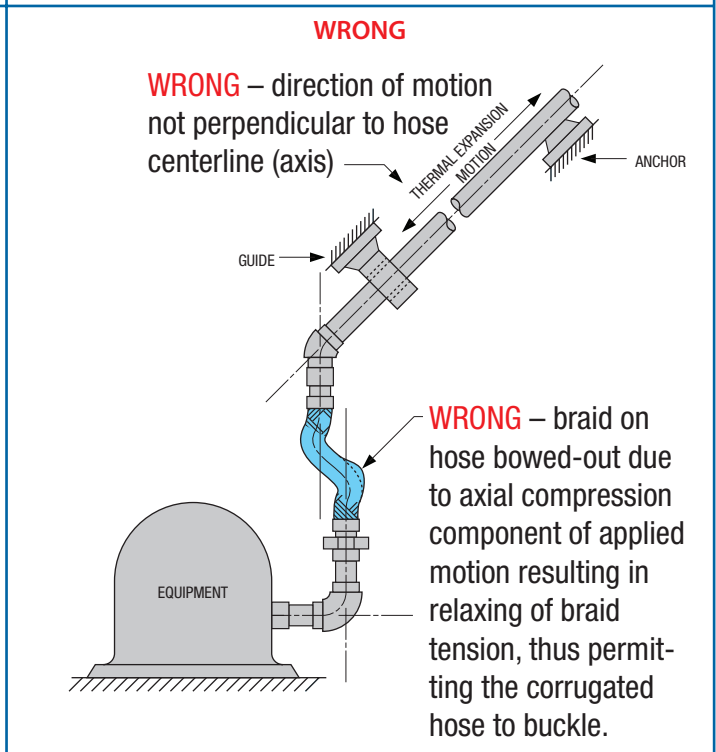
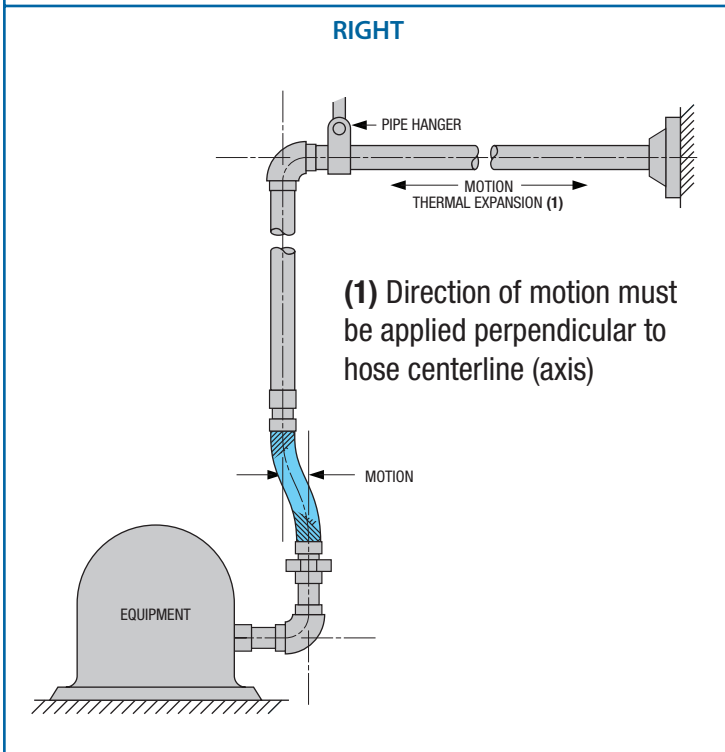
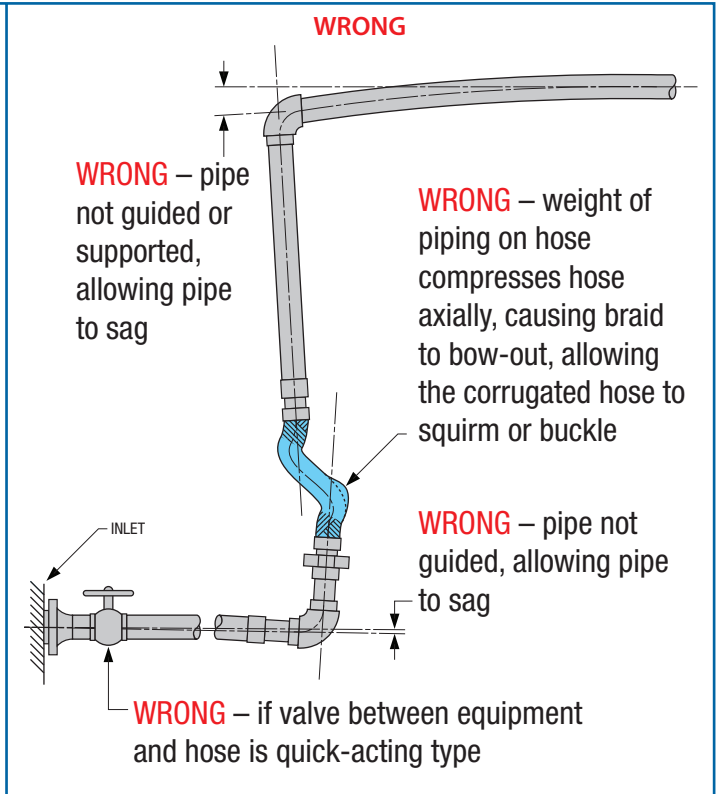
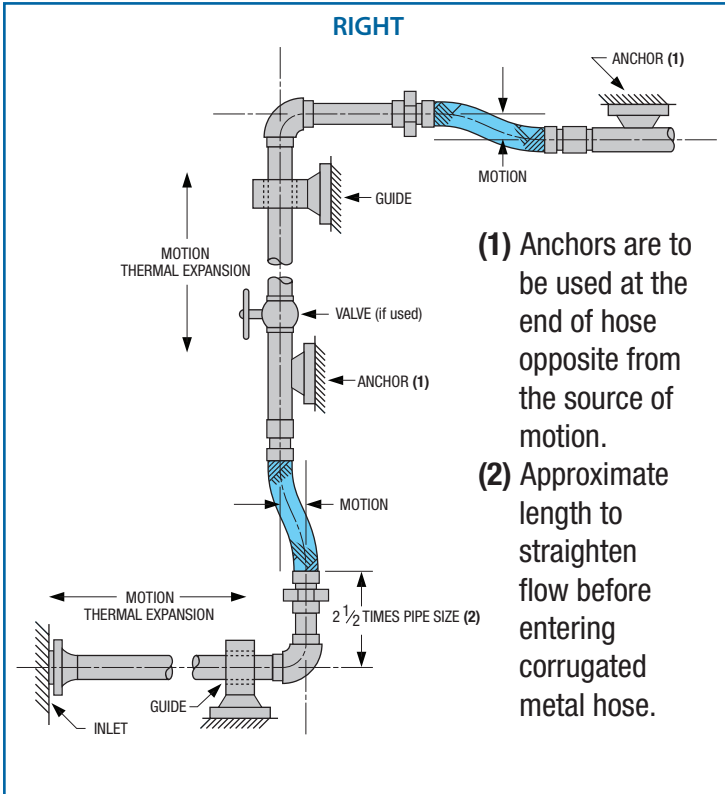

Fractions and Decimal Equivalents

1/64..... .015625	17/64265625	33/6451562	49/64765625
1/3..... .03125	9/32..... .28125	17/32..... .53125	25/32..... .78125
3/64..... .046875	19/64296875	35/6454687	51/64796875
1/16..... .0625	5/16..... .3125	9/16..... .5625	13/16..... .8125
5/64..... .078125	21/64328125	37/64578125	53/64828125
3/32..... .09375	11/3234375	19/3259375	27/3284375
7/64..... .109375	23/64359375	39/64609375	55/64859375
1/8..... .125	3/8..... .375	5/8..... .625	7/8..... .875
9/64..... .140625	25/64390625	41/64640625	57/64890625
5/32..... .15625	13/3240625	21/3265625	29/3290625
11/64171875	27/64421875	43/64671875	59/64921875
3/16..... .1875	7/16..... .4375	11/166875	15/169375
13/64203125	29/64453125	45/64703125	61/64953125
7/32..... .21875	15/3246875	23/3271875	31/3296875
15/64234375	31/64484375	47/64734375	63/64984375
1/4..... .250	1/2..... .500	3/4..... .750	1..... 1.0000

Metric Conversion Factors

Linear

1 Kilometer	= .6214 Mile
1 Meter	= 39.37 Inches
	= 3.2808 Feet
	= 1.0936 Yards
1 Centimeter	= .3937 Inches
1 Millimeter	= .03937 Inches
1 Mile	= 1.609 Kilometer
1 Yard	= .9144 Meter
1 Foot	= 30.48 Centimeter
	= 304.8 Millimeter
1 Inch	= 2.54 Centimeter
	= 25.4 Millimeter

Cubic Measure

1 Cu. meter	= 35.314 Cu. Ft.
	= 1.308 Cu. Yd.
	= 264.2 U.S. Gallons
1 Cu. Centimeter	= .061 Cu. Inch
1 Liter	= 0.0353 Cu. Foot
	= 0.2642 U.S. Gallons
	= 1.0567 U.S. Quart
1 Cu. Yard	= 0.7645 Cu. Meter
1 Cu. Foot	= 0.02832 Cu. Meter
	= 28.317 Liters
1 Cu. Inch	= 16.38716 Cu. Meters
1 U.S. Gallon	= 3.785 Liters
1 U.S. Quart	= 0.946

Pressure

1 Kilogram Per. Sq. Millimeter	= 1422.32 Lb.s Per Sq. Inch
1 Kilogram Per. Sq. Centimeter	= 14.223 Lb.s Per Sq. Inch
1 Kilogram Meter	= 7.233 Foot Lb.s
1 Pound Per Sq. Inch	= 0.0703 Kilogram Per Sq. Centimeter

Temperature

$$^{\circ}\text{F} = (1.8 \times ^{\circ}\text{C}) + 32$$

$$^{\circ}\text{C} = (^{\circ}\text{F} - 32) \times 0.555$$

Square

1 Sq. Kilometer	= .3861 Sq. Mile
1 Sq. Meter	= 10.764 Sq. Ft.
	= 1.196 Sq. Yd.
1 Sq. Centimeter	= .155 Sq. Inch
1 Sq. Millimeter	= 0.00155 Sq. Inch
1 Sq. Mile	= 2.5899 Sq. Kilometer
1 Sq. Yard	= 0.836 Sq. Meter
1 Sq. Foot	= 0.0929 Sq. Meter
	= 929 Sq. Centimeter
1 Sq. Inch	= 6.452 Sq. Centimeter
	= 645.2 Sq. Millimeter

Weight

1 Metric Ton	= 0.9842 Ton (2240 Lb.s)
	= 2204.6 Lb.s
1 Kilograms	= 2.2046 Lb.s
	= .35.274 Oz.s Avoirdupois
1 Gram	= 0.03215 Oz.s Troy
	= 0.03527 Oz.s Avoirdupois
	= 15.432 Grains
1 Ton (2240 Lb.s)	= 1.016 Metric Ton
	= 1016 Kilogram
1 Pound	= 0.4536 Kilogram
	= 453.6 Grams
1 Oz.s Avoirdupois	= 28.35 Grams
1 Oz.s Troy	= 31.013 Grams
1 Grain	= 0.0648 Gram

Metric Abbreviations

Centimeter	= CM
Kilogram	= KG
Kilometer	= KM
Liter	= L
Meter	= M
Millimeter	= MM

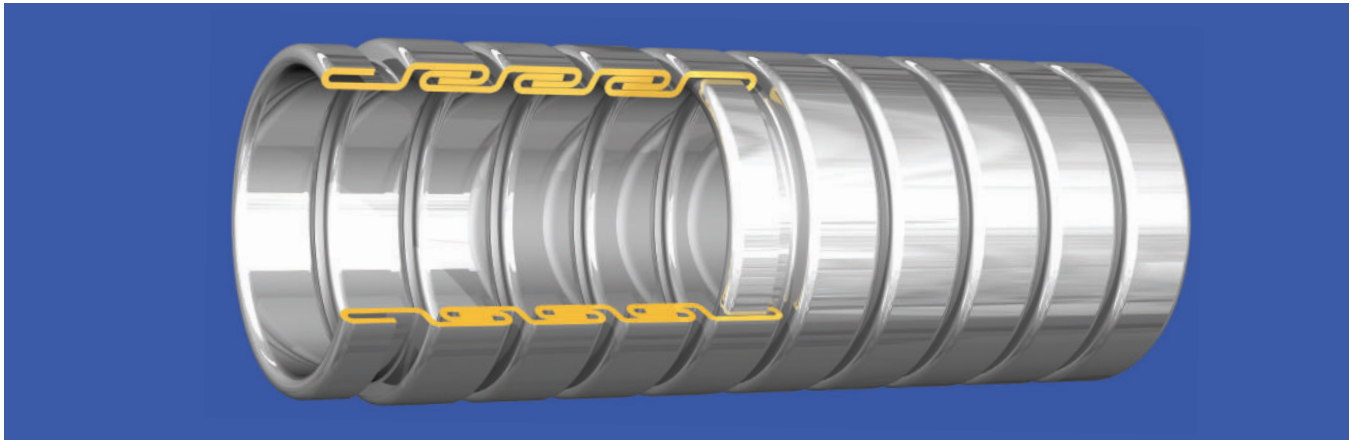

RT-6

APPLICATIONS:

Auto heater tubing, Ventilating ducting, Automotive exhaust, Moderate suction lines, Dust collecting Ducting, Refrigeration tubing armor, Air Blower ducting, Wiring conduit, Carburetor air intake.

SIZE RANGE:

3/16" to 6" I.D. inclusive.
Larger sizes may be available - please contact the Factory for more information.

CONSTRUCTION:

Fully interlocked

METALS:

Stainless Steel, Galvanized Steel, Brass, Bronze, and Monel

METAL THICKNESS:

.010 inches - .012 inches

TEMPERATURE RATING

Galvanized Steel: Up to 200C/392F
T304 Stainless Steel: Up to 454C/850F

Nominal I.D. (Inches)	Nominal O.D. (Inches)	Minimum Inside Bend Diameter (Inches)	Weight Foot "100" Feet
3/16	0.281	3.000	11.000
1/4	0.375	3.000	11.000
3/8	0.500	4.000	14.000
1/2	0.625	6.000	16.000
5/8	0.750	6.500	18.000
3/4	0.875	6.500	20.000
7/8	1.000	7.000	24.000
1	1.130	7.500	28.000
1 1/8	1.260	8.500	32.000
1 1/4	1.380	9.500	36.000
1 3/8	1.510	10.000	38.000
1 1/2	1.650	11.000	48.000
1 5/8	1.780	12.000	52.000
1 3/4	1.900	13.000	58.000
1 7/8	2.030	14.000	60.000
2	2.160	15.000	66.000
2 1/8	2.280	15.500	72.000
2 1/4	2.410	16.500	76.000
2 3/8	2.530	17.500	81.000
2 1/2	2.660	18.500	85.000
2 3/4	2.910	20.000	93.000
2 7/8	3.030	21.000	97.000
3	3.160	22.000	102.000
3 1/4	3.410	24.000	110.000
3 1/2	3.660	26.000	118.000
3 3/4	3.910	27.000	127.000
4	4.160	29.000	135.000
4 1/2	4.660	33.000	152.000
5	5.170	37.000	168.000
6	6.170	44.000	200.000

Numbers based on strip thickness of .010" - .012"
Specifications for other sizes not shown and are available on application.

DESIGN AND APPLICATIONS GUIDE

The selection of the correct metal hose is critical to insure optimum field performance. To accomplish this, there are a number of important applications requirements that must be known. The guide below will

help you identify the requirements, and design the most cost effective, engineering sound product.

The word “STAMPED” is useful as a checklist of applications requirements to be considered.

Consider	Check for . . .	Refer to . . .
S ize/Hose & Fittings	<ul style="list-style-type: none"> • Size of existing piping and mating fittings. • Flow requirements. 	<ul style="list-style-type: none"> • “Hose Technical Data” pages
T emperature	<ul style="list-style-type: none"> • Maximum service temperature of the application. • Maximum allowable service temperature rating for hose and fitting alloys. • Reduced operating pressures at elevated temperature. 	<ul style="list-style-type: none"> • “Metal Hose Selection Factors” pages for maximum service temperature for alloys and conversion factors
A lloy/Hose & Fittings	<ul style="list-style-type: none"> • Corrosion resistance of hose and fittings alloys for the media conveyed. • Maximum service temperature and pressure for the alloy selected. 	<ul style="list-style-type: none"> • “Corrosion Chart” pages • “Metal Hose Selection Factors” pages for maximum service temperature for alloys and conversion factors
M otion & Application	<ul style="list-style-type: none"> • Type of motion—angular, axial, offset, radial, random, vibration, amount and frequency. • Hose type best suited for application and motion, including external durability requirements. • Cycle life requirement. 	<ul style="list-style-type: none"> • “Corrosion Chart” pages • “Metal Hose Selection Factors” pages for motion applications
P ressure	<ul style="list-style-type: none"> • Burst, test and operating pressure. • Constant, pulsating or shock pressures. Operating pressure at elevated temperature. • Braid selection to maximize pressure/minimize cost. 	<ul style="list-style-type: none"> • “Metal Hose Selection Factors” pages for pressure definitions • “Metal Hose Selection Factors” pages for maximum service temperature and conversion factors • “Hose Technical Data” pages
E nd Fitting Attachment	<ul style="list-style-type: none"> • Methods of attachment applicable to type and alloy of hose and fittings. • Maximum temperature for alloys and methods of attachment. 	<ul style="list-style-type: none"> • “Metal Hose Selection Factors” pages for maximum service temperature of alloys page • “Corrugated Metal Hose Fitting” pages
D eveloped Assembly Length	<ul style="list-style-type: none"> • Minimum hose live length for type of motion. • Hose assembly length with fittings (overall length) 	<ul style="list-style-type: none"> • “Metal Hose Selection Factors” pages for assembly life length, motion and vibration. • “Hose Technical Data” pages

NOTICE: This Engineering Guide No. 350 is to assist you in the selection and application of flexible metal hose for your particular requirements. The information and data contained in this Engineering Guide are the result of years of **our** experience and research in flexible metal hose. As such it is the best information and data available to us as of the date of printing. Progress is part of any dynamic program of research and development, such as the Company sponsors, so that all information and data contained herein are subject to change (without notice) at any time.

Should you be unable to determine a specification for a particular application, we solicit receiving details describing the application so that we may make a recommendation. Because we do not supervise or control the installation and use of our products, **we cannot be responsible for their performance or for the improper application and usage of the data.**



Worldwide Leader for Hose of. . .

Wilcox Hose®



Fluoropolymer

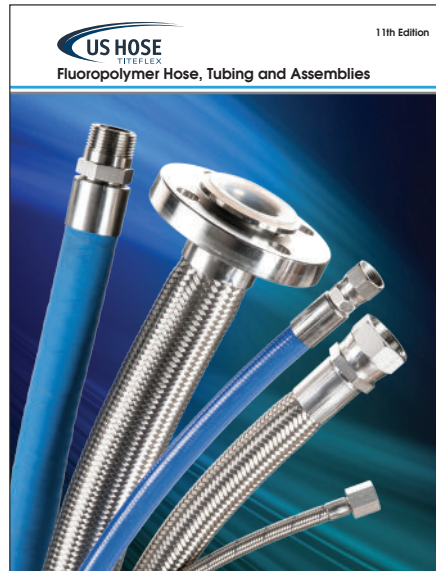

Metal

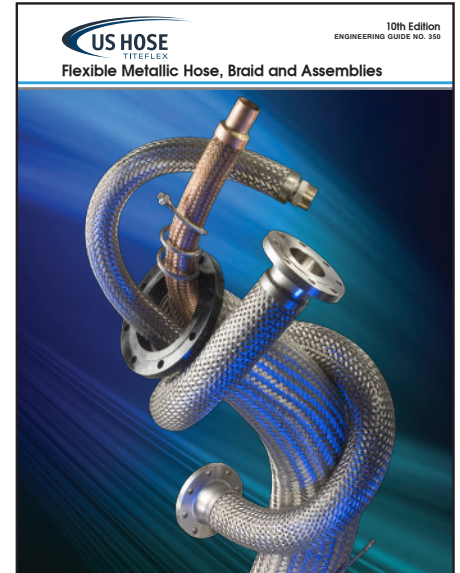

815 Forestwood Drive
Romeoville, Illinois 60446
815/886-1140
800/473-0474
Fax 815/886-4550
E-mail: customersupport@ushose.net

12120 Beaumont Highway
Houston, Texas 77049.U.S.A.
888/919-0400 • Fax 281-458-7809
281/458-0400
E-mail: Willcoxsales@ushose.net

TITEFLEX
603 Hendee Street
Springfield, MA 01139-0054
T 413-739-5631 T 1-800-765-2525
F 413-788-7593



Specifications subject to change without notice.
Printed in U.S.A. ©2024 US Hose Corporation